

## XCD-545

(Standard for single section assemblies)  
\*Grille dimensions furnished approximately 1/2" (13) undersize.

The XCD-545 aluminum grille is designed in accordance with ICC 500 (2020), FEMA P-361 (2015) and FEMA P-320 (2014) guidelines for storm shelters and safe rooms. It offers exceptional protection against wind pressures, rain, and debris impacts produced by tornadoes and hurricanes. The XCD-545 is a UL Classified Windstorm Rated Assembly with a design pressure of 300 psf and has been impact-tested using 15-lb 2 x 4 timbers launched at 100 mph.

For flange-mount installation, the XCD-545 may be sized to cantilever forward of the wall opening (external mount) or slip into the opening (internal mount). The XCD-545 is also available with a non-flanged frame and continuous installation angles.

## Standard Construction

**Material:** Aluminum

**Frame:** 5-1/2" deep x 1/4" thick (140 x 6) channel

**Blades:** 3/16" (5) thick horizontal chevron

**Screen:** 5/8" x 0.050" (15.9 x 1.3) expanded and flattened aluminum

**Mullion:** Visible

**Flange:**

Single section: 5-1/2" (140) on jambs

Multiple section: Single section high - 5-1/2" (140) on top and bottom  
Single section wide - 5-1/2" (140) on jambs

**Factory Finish:** Mill

**Minimum Size:** 12" x 12" (305 x 305)

**Maximum Size:**

Single section: 48" x 96" (1219 x 2438)

Multiple section: Unlimited width x 96" (2438) high or 48" (1219) wide x unlimited height

**Mount Direction:** Internal (flange at front)

## Ratings

**Free Area:** [48" x 48" (1219 x 1219) unit]: 6.1 ft<sup>2</sup> (0.57 m<sup>2</sup>)  
37.9%

**Performance @ Beginning Point of Water Penetration**

**Free Area Velocity:** 1,250 fpm (6.35 m/s)

**Air Volume Delivered:** 7,575 cfm (3.58 m<sup>3</sup>/s)

**Pressure Loss:** 0.28 in.wg. (70 Pa)

**Design Pressure:** 300 psf (14.4 kPa)

Classified as a UL Windstorm Rated Assembly for static pressure, cyclic pressure, and impact resistance

## Options

■ **Alternate bird or insect screens**

■ **Factory finish:**

- High Performance Fluoropolymer
- Baked Enamel ■ Prime Coat

■ **Alternate flanges:**

- Top/bottom flange (single section high only)
- Non-flanged (includes continuous angles for installation)
- Four-sided flange (single section only)

■ **External mount** (flange at rear)



All-Lite certifies that the model XCD-545 shown herein is licensed to bear the AMCA seal. The ratings shown are based on test and procedures performed in accordance with AMCA Publication 511 and comply with the requirements of the AMCA Certified Ratings Program. The AMCA Certified Ratings seal applies to water penetration, air performance and wind driven rain ratings.



**amca** INTERNATIONAL  
[www.amca.org](http://www.amca.org)

**5** year warranty

**NOTE:** Dimensions in parentheses ( ) are millimeters.  
Information is subject to change without notice or obligation.

# PERFORMANCE

## XCD-545

Aluminum Grille  
5-1/2" deep • Horizontal Blade

### Free Area (ft<sup>2</sup>)

		Width (Inches)						
		12	18	24	30	36	42	48
Height (Inches)	12	0.2	0.3	0.4	0.5	0.7	0.8	0.9
	18	0.4	0.6	0.8	1.1	1.3	1.5	1.8
	24	0.5	0.9	1.2	1.6	1.9	2.3	2.6
	30	0.7	1.2	1.6	2.1	2.6	3.0	3.5
	36	0.9	1.5	2.0	2.6	3.2	3.8	4.3
	42	1.1	1.8	2.4	3.1	3.8	4.5	5.2
	48	1.2	2.0	2.8	3.6	4.5	5.3	6.1
	54	1.4	2.3	3.2	4.2	5.1	6.0	6.9
	60	1.6	2.6	3.7	4.7	5.7	6.7	7.8
	66	1.8	2.9	4.1	5.2	6.3	7.5	8.6
	72	1.9	3.2	4.5	5.7	7.0	8.2	9.5
	78	2.1	3.5	4.9	6.2	7.6	9.0	10.4
84	2.3	3.8	5.3	6.8	8.2	9.7	11.2	
90	2.5	4.1	5.7	7.3	8.9	10.5	12.1	
96	2.6	4.4	6.1	7.8	9.5	11.2	12.9	

### Weights (Approximate weight in lbs)

		Width (Inches)						
		12	18	24	30	36	42	48
Height (Inches)	12	18	26	33	41	48	55	63
	18	28	39	50	61	72	83	94
	24	37	52	67	81	96	110	125
	30	47	65	83	101	120	138	156
	36	56	78	100	122	143	165	187
	42	66	91	117	142	167	193	218
	48	75	104	133	162	191	220	249
	54	85	117	150	182	215	248	280
	60	94	130	166	203	239	275	311
	66	104	143	183	223	263	302	342
	72	113	156	200	243	287	330	373
	78	123	170	216	263	310	357	404
84	132	183	233	284	334	385	435	
90	142	196	250	304	358	412	466	
96	151	209	266	324	382	440	497	

### Water Penetration

AMCA defines the beginning point of water penetration as the free area velocity at the intersection of a simple linear regression of test data and the line of 0.01 ounces of water per square foot of free area measured through a 48" x 48" louver during a 15 minute period. The AMCA water penetration test provides a method for comparing louver models and designs as to their efficiency in resisting the penetration of rainfall under specific lab conditions. Potliff recommends that intake louvers are selected with a reasonable margin of safety below the beginning point of water penetration in order to avoid unwanted penetration during severe storm conditions.

#### Beginning Point of Water Penetration = Above 1250 fpm

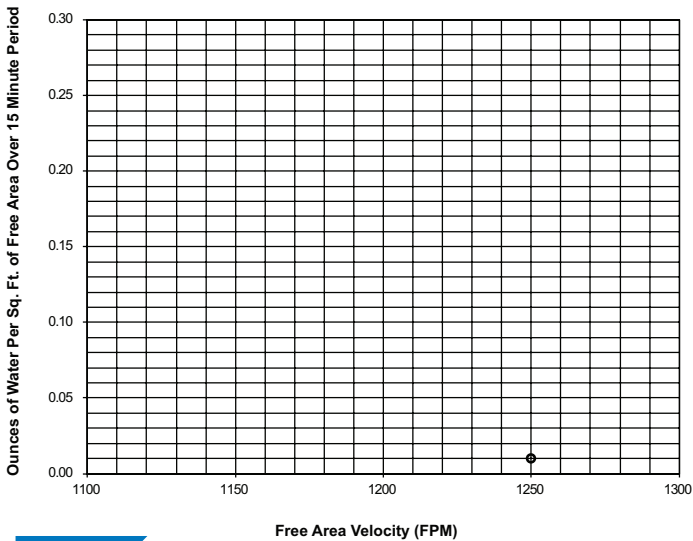

All-Lite certifies that the model XCD-545 shown herein is licensed to bear the AMCA seal. The ratings shown are based on test and procedures performed in accordance with AMCA Publication 511 and comply with the requirements of the AMCA Certified Ratings Program. The AMCA Certified Ratings seal applies to water penetration, air performance and wind driven rain ratings.

### Pressure Loss

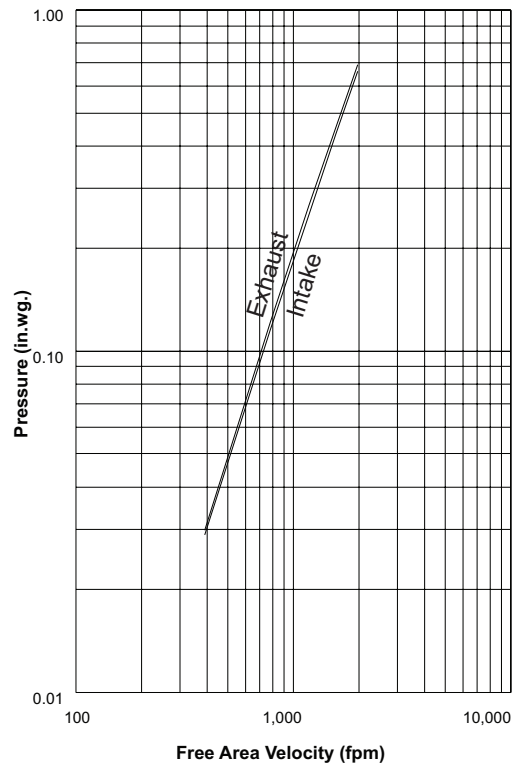

Louver Test Size = 48" x 48" (1219 x 1219)  
Pressure loss tested in accordance with Figure 5.5 of AMCA Standard 500-L. Data corrected to standard air density.

## Wind Driven Rain Performance - AMCA 500L Wind-Driven Rain Test

Wind Velocity	Rainfall	Airflow cfm (m <sup>3</sup> /s)	Core Velocity <sup>1</sup> fpm (m/s)	Free Area Velocity <sup>2</sup> fpm (m/s)	Effectiveness Ratio	Wind-Driven Rain Penetration Class
29 mph	3 in/hr	2,136 (1.0)	198 (1.0)	468 (2.4)	100.0%	A
		3,157 (1.5)	293 (1.5)	691 (3.5)	99.9%	A
		4,201 (2.0)	390 (2.0)	920 (4.7)	99.7%	A
		5,339 (2.5)	496 (2.5)	1,169 (5.9)	97.7%	B
		6,354 (3.0)	590 (3.0)	1,392 (7.1)	95.9%	B
		7,499 (3.5)	697 (3.5)	1,643 (8.3)	91.9%	C
		8,460 (4.0)	786 (4.0)	1,853 (9.4)	90.4%	C
		9,601 (4.5)	892 (4.5)	2,103 (10.7)	80.0%	C
		10,600 (5.0)	985 (5.0)	2,322 (11.8)	59.1%	D

**NOTE:**

1. Core area is the open area of the louver face (face area less louver frame). Core velocity is the airflow divided by core area. Test louver core area is 10.77 ft<sup>2</sup> (1 m<sup>2</sup>).

2. Free area velocity is the airflow divided by free area. Test louver free area is 4.6 ft<sup>2</sup> (0.4 m<sup>2</sup>).

**Wind Driven Rain**

Class	Effectiveness
A	99% and above
B	95% to 98.9%
C	80% to 94.9%
D	below 80%

## Attributes

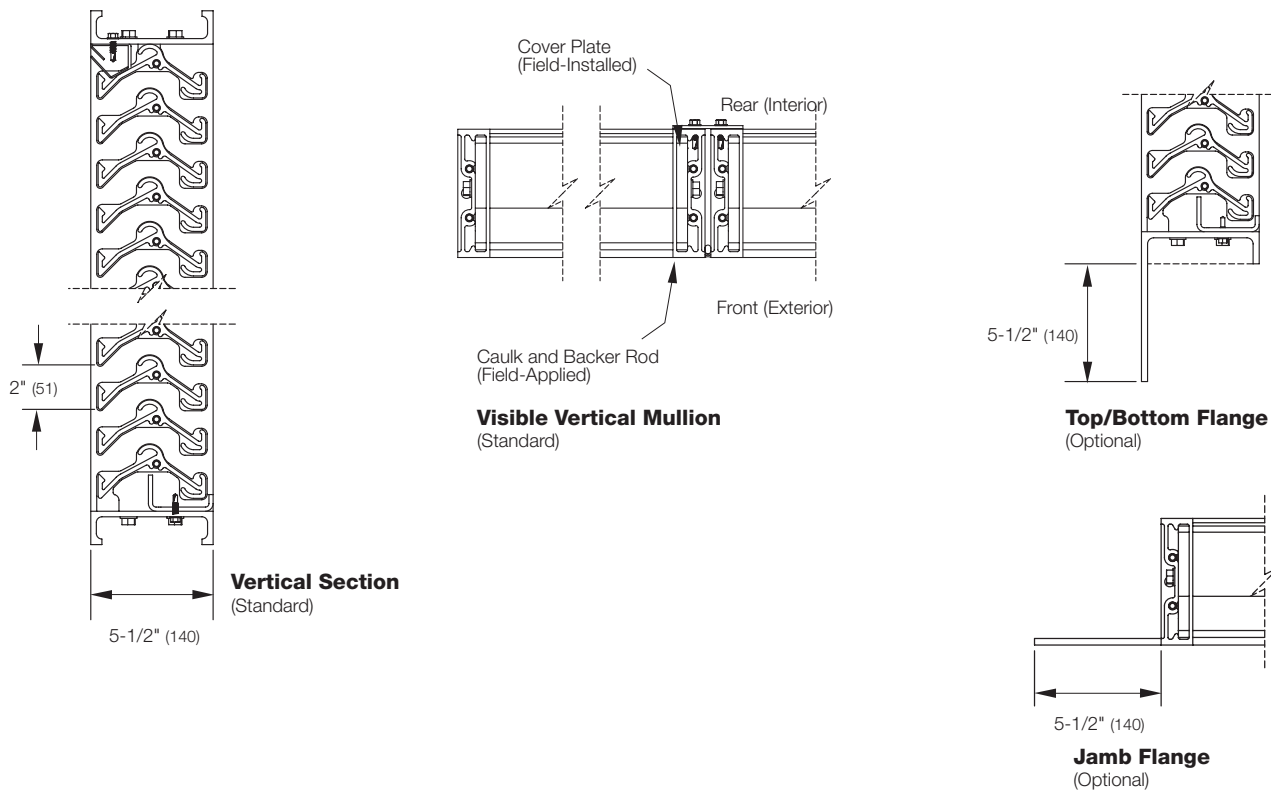

## Anchor/Fastener Requirements

Attachment Method	Attachment Location	Building Substrate	Anchor Type	Min. Edge Distance	Max. Spacing	Min. Embedment Depth
Flange-Mounted (Internal Or External Mount)	Jambs	Grout-Filled Cmu ( $f'm \geq 1500$ Psi)	3/8" x 4" Dewalt Screw-Bolt+	2-1/2"	12"	3-1/4"
		Concrete ( $f'c \geq 4000$ Psi Cracked)	3/8" x 4" Dewalt Screw-Bolt+	2-1/2"	17"	3-1/4"
		Steel (Min 3/16" Thick, $F_y \geq 36$ Ksi)	3/8" Self-Tapping Screw, Gr. 5 Steel*	3/4"	20"	3/16"
	Top/Bottom	Grout-Filled Cmu ( $F'm \geq 1500$ Psi)	3/8" x 4" Dewalt Screw-Bolt+	2-1/2"	6"	3-1/4"
		Concrete ( $f'c \geq 4000$ Psi Cracked)	3/8" x 4" Dewalt Screw-Bolt+	2-1/2"	10"	3-1/4"
		Steel (Min 3/16" Thick, $F_y \geq 36$ Ksi)	3/8" Self-Tapping Screw, Gr. 5 Steel*	3/4"	10"	3/16"
Continuous Angles (Internal Mount Only)	Jambs Shelf Angle Anchors	Grout-Filled Cmu ( $f'm \geq 1500$ Psi)	3/8" x 4" Dewalt Screw-Bolt+	2-1/2"	5"	3-1/4"
		Concrete ( $f'c \geq 4000$ Psi, Cracked)	3/8" x 4" Dewalt Screw-Bolt+	2-1/2"	8"	3-1/4"
	Jambs Cont. Angle Anchors	Concrete ( $f'c \geq 4000$ Psi, Cracked)	3/8" x 4" Dewalt Screw-Bolt+	2-1/2"	8"	3-1/4"
		Steel (Min 3/16" Thick, $F_y \geq 36$ Ksi)	3/8" Self-Tapping Screw, Gr. 5 Steel*	3/4"	10"	3/16"
	Top & Bottom Shelf Angle Anchors	Grout-Filled Cmu ( $f'm \geq 1500$ Psi)	1/2" Through-Bolt W/ Nut & Bearing Plate	2-1/2"	8"	FULL
		Concrete ( $f'c > 4000$ Psi, Cracked)	1/2" Through-Bolt W/ Nut & Bearing Plate	2-1/2"	8"	FULL
Top & Bottom Cont. Angle Anchors	Concrete ( $f'c \geq 4000$ Psi Cracked)	5/8" x 5" Dewalt Screw-Bolt+	4-1/8"	12"	4"	
	Steel (Min 3/16" Thick, $F_y \geq 36$ Ksi)	3/8" Self-Tapping Screw, Gr. 5 Steel*	3/4"	8"	3/16"	

**NOTE:** It is acceptable to substitute 3/8 -16 bolts, nuts, and flat washers instead of 3/8" self-tapping screws.

## Flange Options

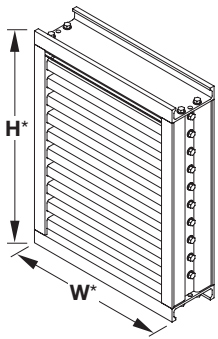

### Non-Flanged

\*Grille dimensions furnished approximately 1/2" (13) undersize

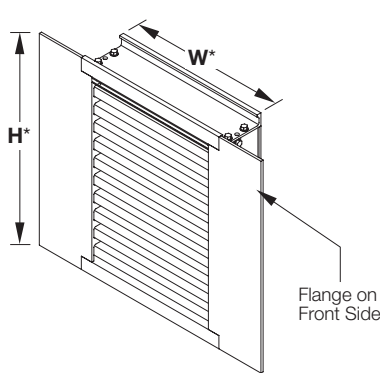

### Jamb Flange/ Internal Mount

(single section wide only) \*Grille dimensions furnished approximately 1/2" (13) undersize

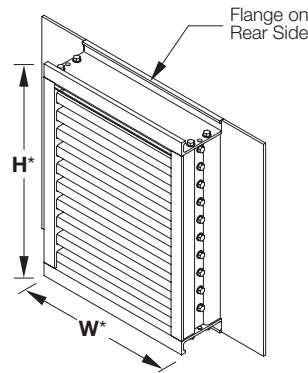

### Jamb Flange/ External Mount

(single section wide only) \*Grille dimensions furnished approximately 3" (76) oversize

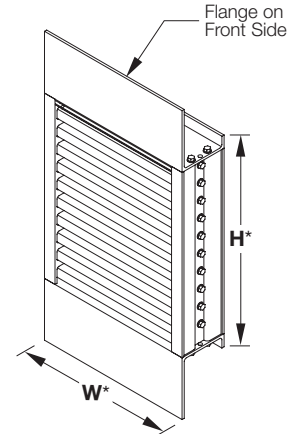

### Top/Bottom Flange Internal Mount

(single section high only) \*Grille dimensions furnished approximately 1/2" (13) undersize

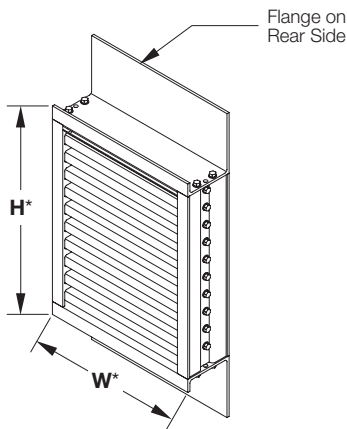

### Top/Bottom Flange External Mount

(single section high only) \*Grille dimensions furnished approximately 3" (76) oversize

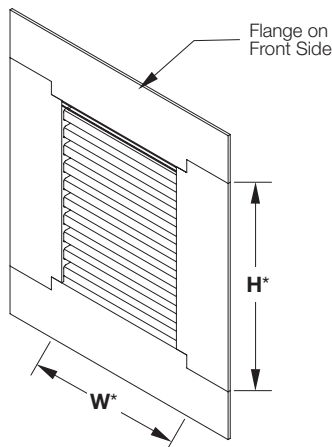

### Four-Sided Flange Internal Mount

(single section only) \*Grille dimensions furnished approximately 1/2" (13) undersize

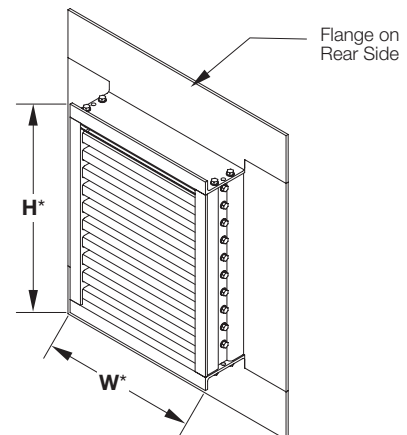

### Four-Sided Flange External Mount

(single section only) \*Grille dimensions furnished approximately 3" (76) oversize