

## Application

The SSA-645 extruded aluminum sunshade is designed to provide distinctive style to a building's exterior while keeping the building cool and saving energy by reducing glare and thermal load. It is ideal for sustainable or 'green' building construction. The SSA-645 is available in a wide array of anodized and painted finishes including custom color matching.

## Standard Construction

**Material:** Mill finish 6063-T5 extruded aluminum.

**Outrigger:** 6" high × 0.250" thick (152 × 6.4) plate with rounded front.

**Blades:** 45° × 0.110" thick (2.8) thick airfoil style.

**Fascia:** 4" diameter × 0.081" thick (102 × 2.1) round tube.

**Minimum Size:** 12" (305) wide.

**Maximum Size:** Single section: 96" (2438) wide.  
 Multiple section: Unlimited

**Projection:** 24" (610), 36" (914), 42" (1067), 48" (1219), and 60" (1524).

**Mounting Bracket:** Exposed.

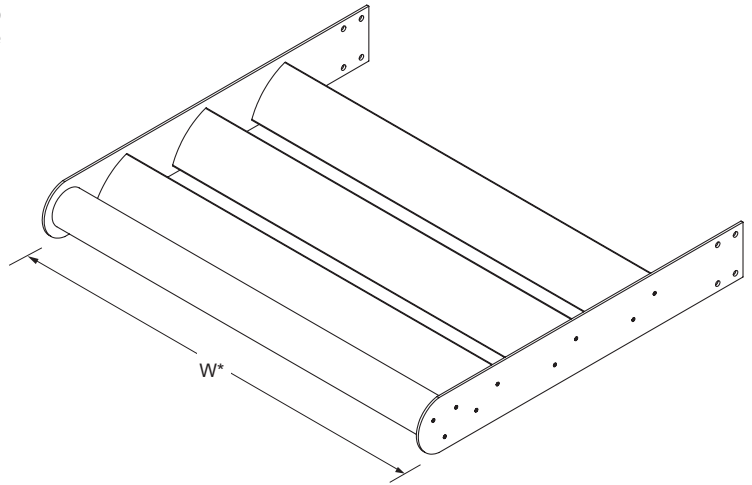

Model **SSA-645**  
 (standard)

\*Dimensions furnished net O.D.  
 (Centerline of mounting bracket to centerline of mounting bracket).

## Options

Factory finish:

- High Performance Fluoropolymer - 100% resin Newlar®/ 70% resin Kynar®
- Baked Enamel
- Clear Anodize
- Integral Color Anodize

- Tapered (top and bottom) outrigger.
- Concealed mounting bracket.
- Strut connection.
- Shroud connection.
- 90° corner.

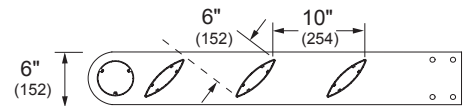

Horizontal Section

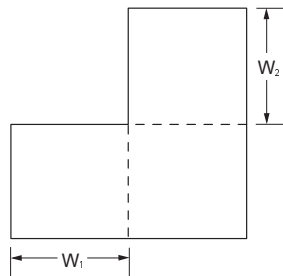

90° Corner

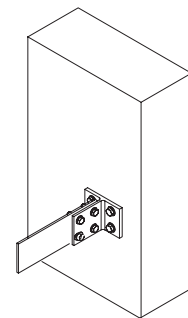

Exposed Mounting Bracket  
 (standard)

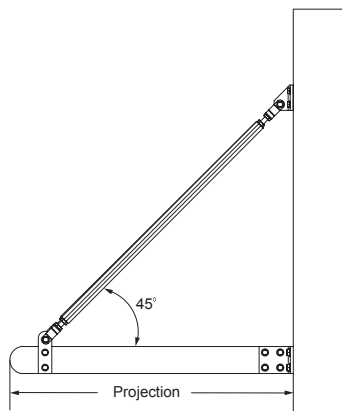

Shroud Connection  
 (optional)

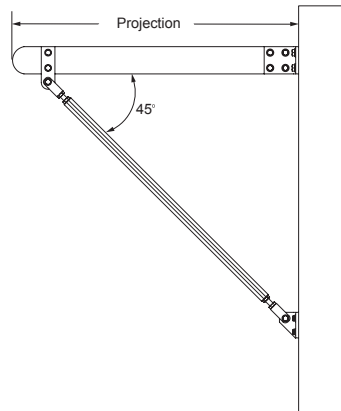

Strut Connection  
 (optional)

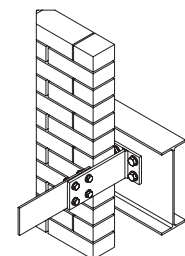

Concealed Mounting Bracket  
 (optional)