

General

The following guidelines provide basic assembly and installation instructions for standard All-Lite extruded aluminum operable blade louvers. Most All-Lite standard louvers are designed to resist a 30 psf wind load.

1. Consult with the Engineer of record for the size, type, and surrounding condition.
2. Refer to job-specific submittal drawings for additional details when provided.
3. Carefully lift louver sections by their frames or support members using multiple lifting points if necessary to avoid distortion, racking or damage. **Do not apply excessive force to a single point and NEVER LIFT UNITS BY LOUVER BLADES, LINKAGE, OR ACTUATOR.** Take necessary precautions to prevent marring the louver finish.
4. Caulk and anchors are by others. Proper isolation (by others) is recommended between aluminum louver components and steel building conditions to prevent corrosion.

Preparation





Louvers and Hardware

1. Locate all crates, boxes, cartons, etc.
2. Remove louvers from packaging, inspect for damage, confirm quantities and sizes with packing list, and organize parts in order of installation. If installation hardware was ordered it will typically be in a separate box.
3. Notify your All-Lite representative immediately of any shortages or shipping damage.

Openings

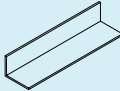
1. Inspect openings for damage, repair as needed, and remove obstructions and debris as required.
2. Verify that openings are square, plumb, and that the louvers will fit properly prior to installation.

Table 1: Installation Hardware

Part	Description		
A-1	Clip Angle (1-1/2" x 2" x 1/8" x 4" long; 6061-T6 Aluminum)		Optional by All-Lite
A-2	Extended Clip Angle (1-1/2" x 2" x 1/8" x 8" long; 6061-T6 Aluminum)		Optional by All-Lite (multi-section high assemblies only)
F-1	#12-14 x 3/4" Hex Head Self-Drilling Screw		Included with clip angles
F-2	1/4"-20 x 1-1/4" Hex- Head Bolt, Locknut and (2) Flat Washers		Included with clip angles (multi-section high assemblies only)
F-3	Anchor to Condition (varies)		Supplied by others

Sill Flashing (if applicable)

1. Locate all sill flashing (by others or optional by All-Lite). Sill flashing is recommended for all multiple section louvers.
2. Confirm that the sill of the opening and the underside of the sill flashing are clean and free of all debris.
3. Apply caulk to the bottom of the opening and firmly set the sill flashing in the caulk. See Figure 1.1.
 - a. For wider openings, multiple pieces of flashing may be necessary in order to cover the entire width. When this occurs, caulk at all overlapping joints and firmly set. See Figure 1.2.
 - b. Closed end flashing pieces (if supplied by All-Lite) will include extra length on each end which must be cut, and manually bent into place to close off the sill flashing ends. Carefully bend up the end tabs and thoroughly caulk the corner seams. See figure 1.3.

Single Section Louver Installation

1. Locate all A-1 anchor clip angles as required to establish proper louver depth and position. See fig. 2.1 for required locations and spacing. (Clip angles are by others or optional by All-Lite.)
2. Place the louver section into the opening. See fig. 2.2, 2.3 and 2.4.
3. Shim around the perimeter of the louver to maintain the proper sealant joint clearance and to level the louver. (Shims are by others, or supplied by All-Lite along with clip angles.) Secure clip angles to wall structure using anchors (by others) as appropriate for the type of substrate.
4. When the louver is level and in the proper position, fasten louver frame to clip angles with minimum #12 screws (by others, or supplied by All-Lite along with clip angles.) Secure clip angles to wall structure using anchors by others as appropriate for the type of substrate.
5. Install backer rod and caulk around the entire perimeter of **sill flashing to allow for drainage.**

Multiple Section Louver Installation

1. Locate all A-1 anchor clip angles as shown in fig. 3.1 (Clip angles are by others or optional by All-Lite).
2. Install the lower left section (as viewed from the exterior) following steps 2-4 for single sections above. After this, if more than one section wide, install the next section to the right, following the procedure in steps 2-4 above. Moving from left to right and then bottom to top, install remaining sections and secure with clip angles as shown. See fig 3.1 and 3.4. At horizontal splice joints (if present), use A-2 extended angles to connect to a structural member (by others) behind the louver. For these splice connections see fig. 3.3.
3. Install backer rod and caulk around the entire perimeter of the louver, and between louver sections, as required. **Do not caulk between louver and sill flashing to allow for drainage.**

Actuator Connection

1. All electrical and pneumatic connections should be done in accordance with local code requirements and actuator installation documentation. Before you apply power to actuator, verify power requirements. After appropriate power has been connected to the actuator, cycle the louver to ensure proper operation.

Installation Details

Extruded Aluminum Operable Louver Installation Instructions

Sill Flashing

Fig 1.1 Sill Flashing Vertical Section

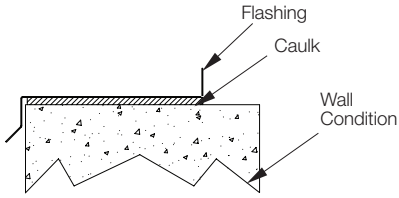

Fig 1.2 Sill Flashing Assembly

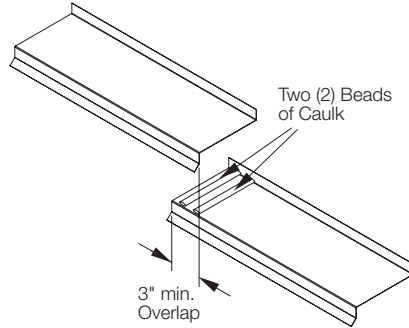
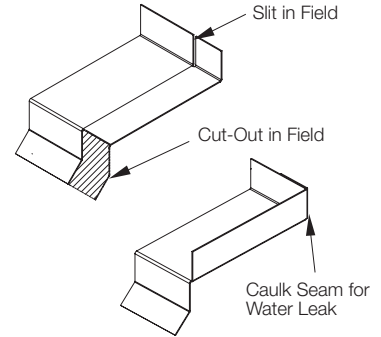

Fig 1.3 Closed End Sill Flashing



Single Section Louver Installation

Fig 2.1 Clip Angle - Single Section Louver

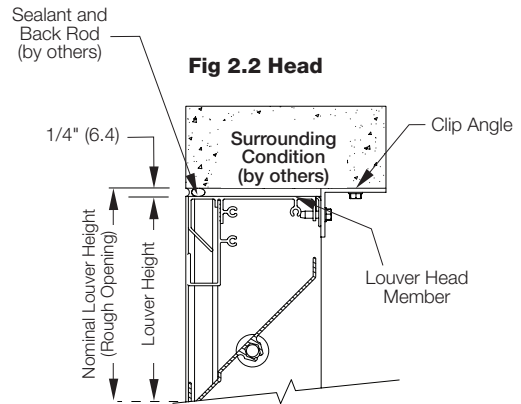
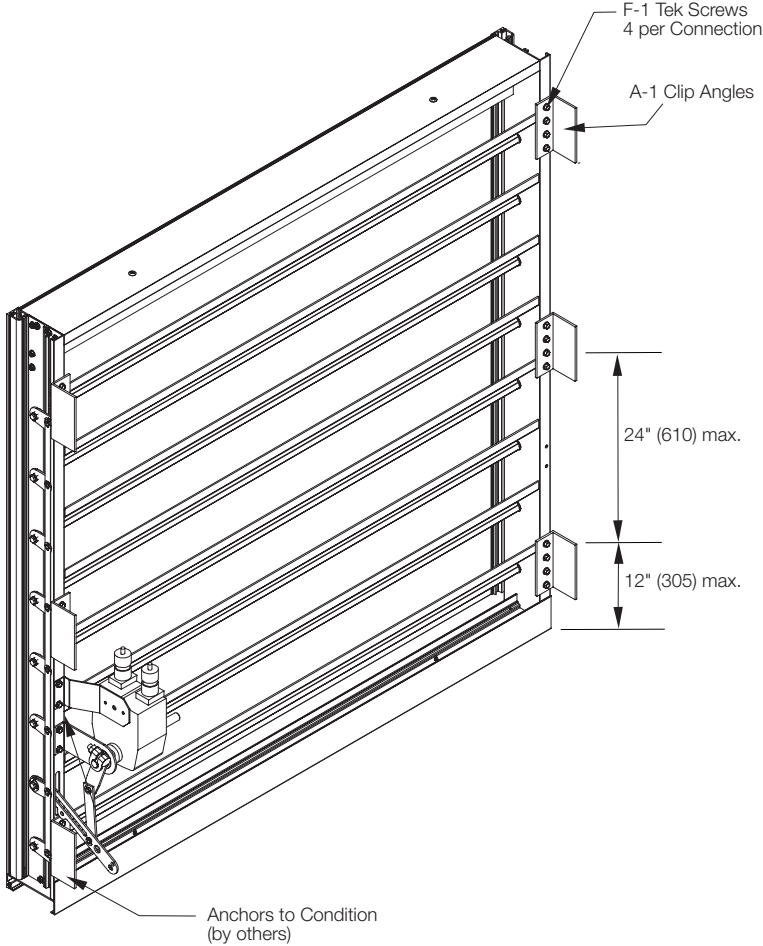

Fig 2.3 Jamb

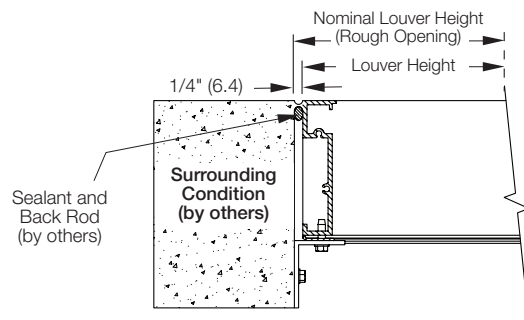
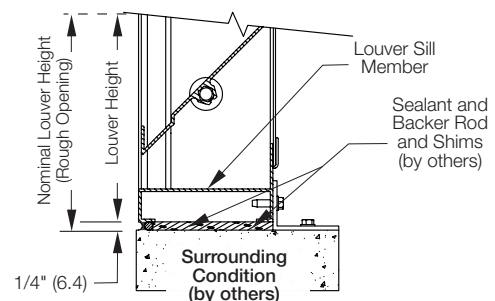

Fig 2.4 Sill



Installation Details

Operable Louver

Installation Instructions

Multiple Section Louver Installation

Fig 3.1 Clip Angle - Multiple Section Louver

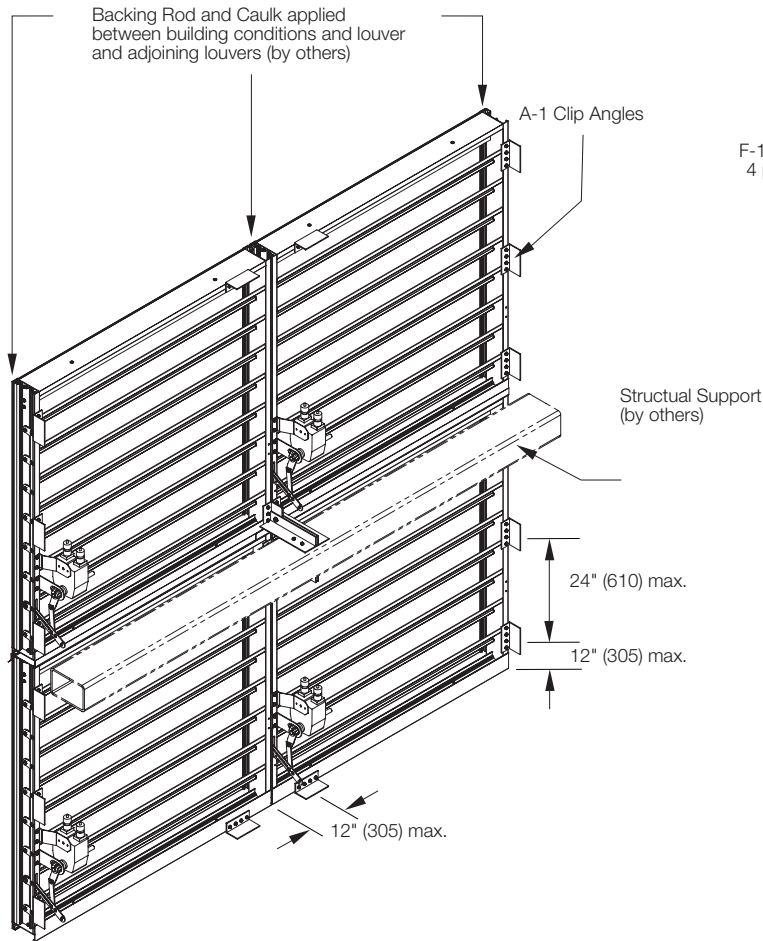

Fig 3.3 Interior Jamb Detail

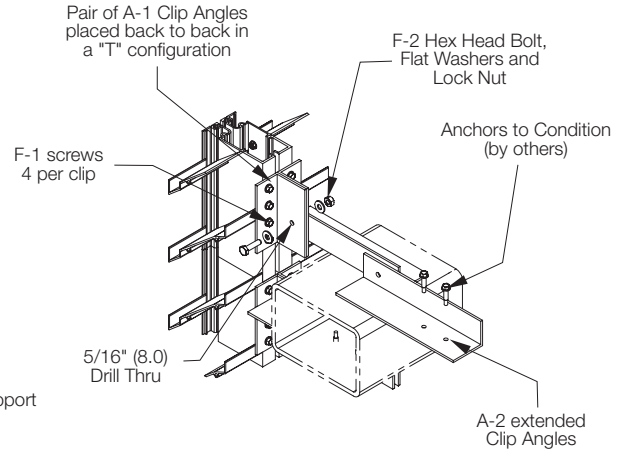

Fig 3.4 Visible Mullion Interior

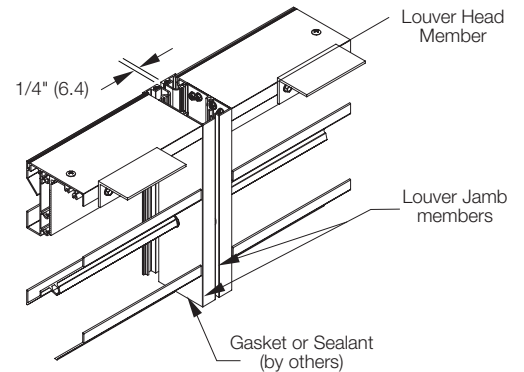

Fig 3.2 Multi-Section High

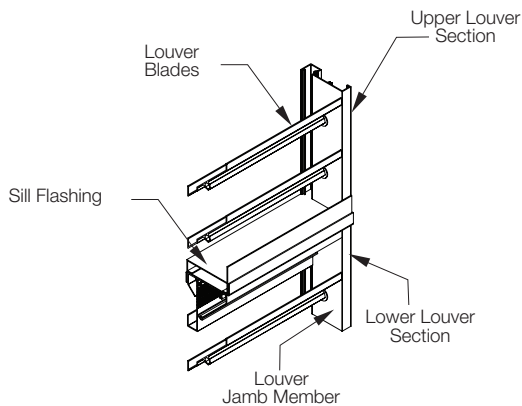

Fig 3.5 Visible Mullion

