

# ALL-LITE

## ECD-745

Extruded Aluminum Louver  
7" deep • 45° Horizontal Drainable Blade

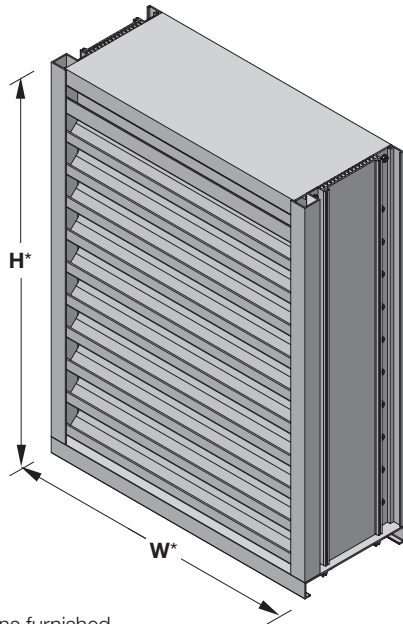

### ECD-745

(standard)

\*Louver dimensions furnished approximately 1/2" (13) undersize.

## Ratings

**Free Area:** [48" x 48" (1219 x 1219) unit]: 8.1 ft<sup>2</sup> (0.75m<sup>2</sup>)  
50.6%

### Performance @ Beginning Point of Water Penetration

**Free Area Velocity:** 1,218 fpm (6.19 m/s)

**Air Volume Delivered:** 9,866 cfm (4.66 m<sup>3</sup>/s)

**Pressure Loss:** 0.57 in.wg. (141 Pa)

**Velocity @ 0.15 in.wg. Pressure Loss:** 631 fpm (3.21 m/s)

**Design Load:** 30 psf

**5** year  
warranty



### Certified Ratings:

All-Lite certifies that the model ECD-745 shown herein is licensed to bear the AMCA seal. The ratings shown are based on test and procedures performed in accordance with AMCA Publication 511 and comply with the requirements of the AMCA Certified Ratings Program. The AMCA Certified Ratings seal applies to air performance, water penetration and wind-driven rain ratings.

The ECD-745 offers exceptional protection against wind-driven rain under the most severe conditions and is ideally suited for high wind areas or applications that are sensitive to wind-driven rain penetration. The ECD-745 incorporates horizontal blades and is available in a wide array of anodized and painted finishes including custom color matching.

## Standard Construction

**Material:** Mill finish 6063-T5 extruded aluminum

**Frame:** 7" deep x 0.081" thick (178 x 2) channel

**Blades:** 45° x 0.081" (2) thick horizontal drainable style

**Screen:** 1/2" x 0.063" (12.7 x 1.6) expanded and flattened aluminum

**Minimum Size:** 4.5" x 6.5" (114 x 165)

### Maximum Size:

Single section: 60" x 120" (1524 x 3048)

120" x 60" (3048 x 1524)

Multiple section: Unlimited

## Options

### ■ Factory finish:

- High Performance Fluoropolymer
- Prime Coat
- Baked Enamel
- Clear Anodize
- Integral Color Anodize

### ■ Frame Options:

- 1-1/2" (38) flange frame
- Custom-size flange
- Stucco flange
- Glazing frame

### ■ Installation Hardware

- Clip angles
- Continuous angles

### ■ Alternate bird or insect screens

### ■ Insulated or non-insulated blank-off panels

### ■ Hidden Vertical Mullion

### ■ Filter racks

### ■ Hinged frame

### ■ Subframe

### ■ Head and/or sill flashing

### ■ Frame closure

### ■ Burglar Bars

### ■ Net OD (actual size)

**NOTE:** Dimensions in parentheses ( ) are millimeters.  
Information is subject to change without notice or obligation.

# PERFORMANCE

## ECD-745

Extruded Aluminum Louver  
7" deep • 45° Horizontal Drainable Blade

### Free Area (ft<sup>2</sup>)

		Width (Inches)																			
		4.5	12	18	24	30	36	42	48	54	60	66	72	78	84	90	96	102	108	114	120
Height (Inches)	6	0.01	0.04	0.1	0.1	0.1	0.1	0.2	0.2	0.2	0.2	0.3	0.3	0.3	0.3	0.4	0.4	0.4	0.4	0.5	0.5
	12	0.1	0.3	0.5	0.6	0.8	1.0	1.1	1.3	1.5	1.7	1.8	2.0	2.2	2.3	2.5	2.7	2.9	3.0	3.2	3.4
	18	0.1	0.5	0.8	1.2	1.5	1.8	2.1	2.4	2.8	3.1	3.4	3.7	4.0	4.3	4.7	5.0	5.3	5.6	5.9	6.3
	24	0.2	0.8	1.2	1.7	2.2	2.6	3.1	3.6	4.0	4.5	5.0	5.4	5.9	6.3	6.8	7.3	7.7	8.2	8.7	9.1
	30	0.3	1.0	1.6	2.2	2.9	3.5	4.1	4.7	5.3	5.9	6.5	7.1	7.7	8.4	9.0	9.6	10.2	10.8	11.4	12.0
	36	0.3	1.3	2.0	2.8	3.5	4.3	5.1	5.8	6.6	7.3	8.1	8.8	9.6	10.4	11.1	11.9	12.6	13.4	14.1	14.9
	42	0.4	1.5	2.4	3.3	4.2	5.1	6.0	6.9	7.8	8.7	9.7	10.6	11.5	12.4	13.3	14.2	15.1	16.0	16.9	17.8
	48	0.4	1.8	2.8	3.9	4.9	6.0	7.0	8.1	9.1	10.2	11.2	12.3	13.3	14.4	15.4	16.5	17.5	18.6	19.6	20.7
	54	0.5	2.0	3.2	4.4	5.6	6.8	8.0	9.2	10.4	11.6	12.8	14.0	15.2	16.4	17.6	18.8	20.0	21.2	22.4	23.6
	60	0.6	2.2	3.6	4.9	6.3	7.6	9.0	10.3	11.7	13.0	14.3	15.7	17.0	18.4	19.7	21.1	22.4	23.8	25.1	26.4
	66	0.6	2.5	4.0	5.5	7.0	8.5	9.9	11.4	12.9	14.4	15.9	17.4	18.9	20.4	21.9	23.4	24.9	26.4	27.8	29.3
	72	0.7	2.7	4.4	6.0	7.6	9.3	10.9	12.6	14.2	15.8	17.5	19.1	20.8	22.4	24.0	25.7	27.3	28.9	30.6	32.2
78	0.7	3.0	4.8	6.5	8.3	10.1	11.9	13.7	15.5	17.3	19.0	20.8	22.6	24.4	26.2	28.0	29.8	31.5	33.3	35.1	
84	0.8	3.2	5.2	7.1	9.0	10.9	12.9	14.8	16.7	18.7	20.6	22.5	24.5	26.4	28.3	30.3	32.2	34.1	36.1	38.0	
90	0.9	3.5	5.5	7.6	9.7	11.8	13.9	15.9	18.0	20.1	22.2	24.2	26.3	28.4	30.5	32.6	34.6	36.7	38.8	40.9	
96	0.9	3.7	5.9	8.2	10.4	12.6	14.8	17.1	19.3	21.5	23.7	26.0	28.2	30.4	32.6	34.9	37.1	39.3	41.5	43.8	
102	1.0	4.0	6.3	8.7	11.1	13.4	15.8	18.2	20.6	22.9	25.3	27.7	30.0	32.4	34.8	37.2	39.5	41.9	44.3	46.6	
108	1.0	4.2	6.7	9.2	11.8	14.3	16.8	19.3	21.8	24.3	26.9	29.4	31.9	34.4	36.9	39.5	42.0	44.5	47.0	49.5	
114	1.1	4.4	7.1	9.8	12.4	15.1	17.8	20.4	23.1	25.8	28.4	31.1	33.8	36.4	39.1	41.8	44.4	47.1	49.8	52.4	
120	1.2	4.7	7.5	10.3	13.1	15.9	18.7	21.6	24.4	27.2	30.0	32.8	35.6	38.4	41.2	44.1	46.9	49.7	52.5	55.3	

### Water Penetration

AMCA defines the beginning point of water penetration as the free area velocity at the intersection of a simple linear regression of test data and the line of 0.01 ounces of water per square foot of free area measured through a 48" x 48" louver during a 15 minute period. The AMCA water penetration test provides a method for comparing louver models and designs as to their efficiency in resisting the penetration of rainfall under specific lab conditions. We recommend that intake louvers are selected with a reasonable margin of safety below the beginning point of water penetration in order to avoid unwanted penetration during severe storm conditions.

**Beginning Point of Water Penetration = 1,218 fpm**

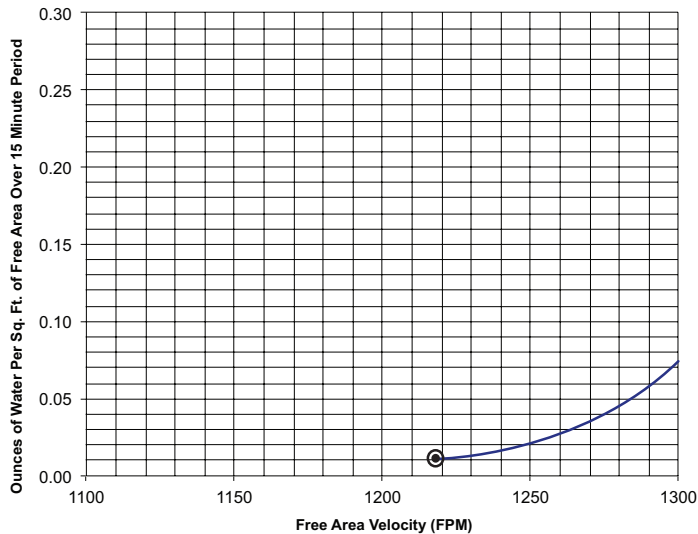

### Pressure Loss

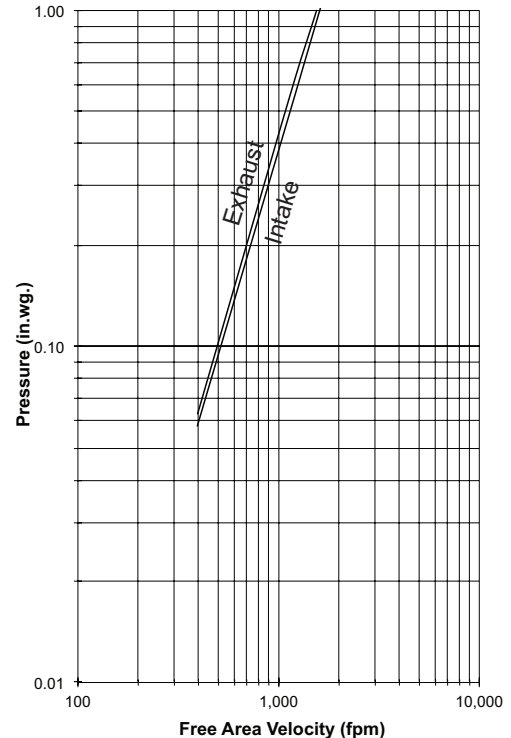

Louver Test Size = 48" x 48" (1219 x 1219)  
Pressure loss tested in accordance with Figure 5.5 of AMCA Standard 500-L. Data corrected to standard air density.

# PERFORMANCE

## ECD-745

Extruded Aluminum Louver  
7" deep • 45° Horizontal Drainable Blade

### Wind Driven Rain Performance - AMCA 500L Wind-Driven Rain Test

Wind Velocity	Rainfall	Airflow	Core Velocity <sup>1</sup>	Effectiveness Ratio	Water-Driven Rain Penetration Class	Discharge Loss Class <sup>2</sup>
29 mph	3 in/hr	6,260 cfm	581 fpm	99.6%	A	3
50 mph	8 in/hr	5,312 cfm	493 fpm	99.2%	A	

**NOTE:**

1. Core area is the open area of the louver face (face area less louver frame). Core velocity is the airflow divided by core area. Test louver core area is 10.77 ft<sup>2</sup> (1 m<sup>2</sup>).

2. Discharge Loss Coefficient is calculated by dividing the louver's actual airflow rate by the theoretical airflow rate for an unobstructed opening. The higher the coefficient, the lower the resistance to airflow.

**Wind Driven Rain**

Class	Effectiveness
A	99% and above
B	95% to 98.9%
C	80% to 94.9%
D	below 80%

**Discharge Loss**

Class	Coefficient
1	0.4 and above
2	0.3 to 0.399
3	0.2 to 0.299
4	0.199 and below

## Attributes

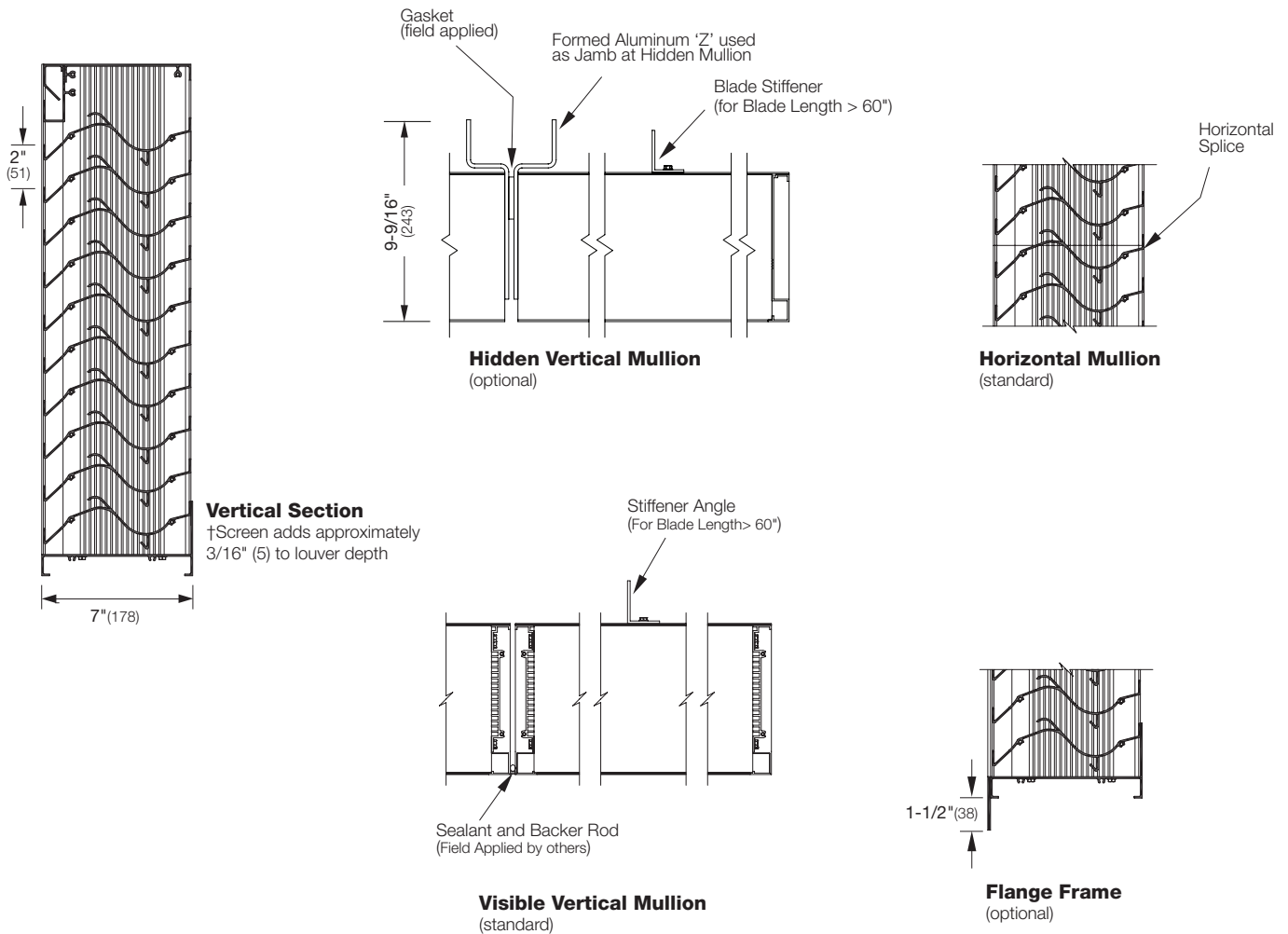

# Supplemental Options

# ECD-745

Extruded Aluminum Louver  
7" deep • 45° Horizontal Drainable Blade

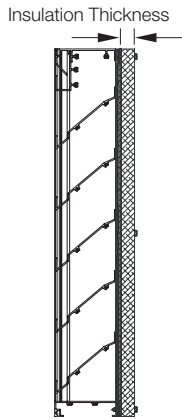

**Blank-Off Options**  
Non-Insulated and Gasketed  
1" Insulated (4.25 R-value)  
2" Insulated (8.75 R-value)

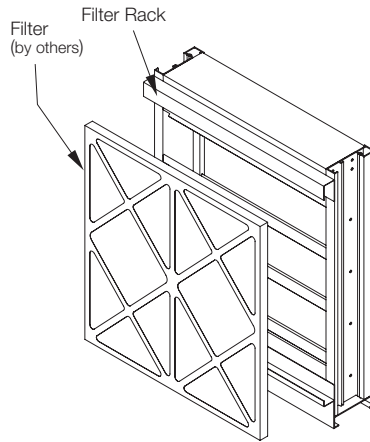

**Filter Rack**

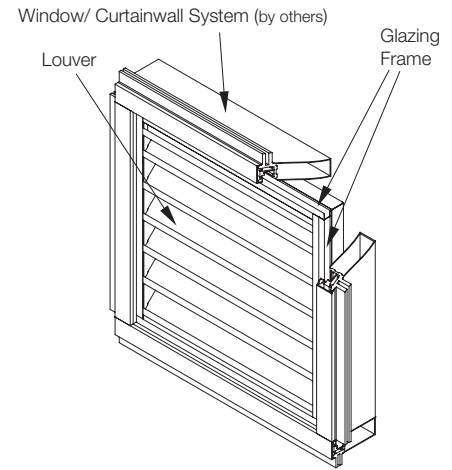

**Glazing Frame**

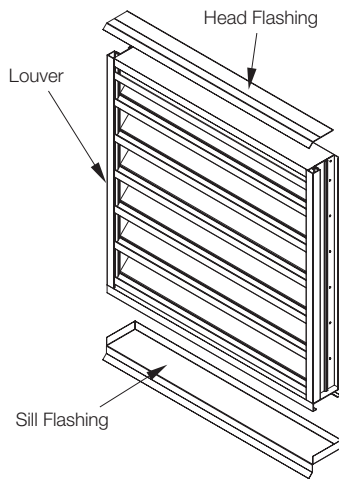

**Flashing Options**  
Head and Sill Available

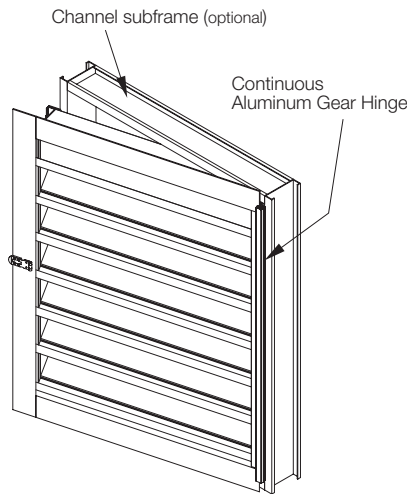

**Hinge and Subframe**  
Right or Left Side Option Available

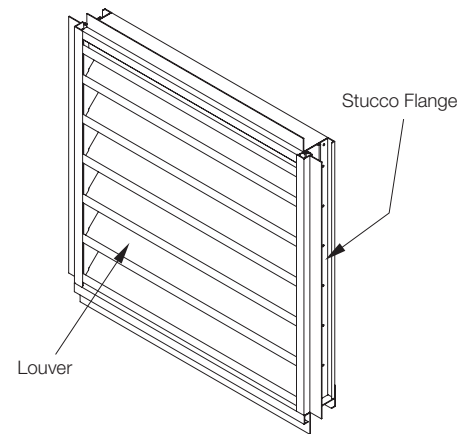

**Stucco Flange**  
3/4" (19) Standard Stucco Depth