

ALL-LITE

ECD-635

Extruded Aluminum Louver
6" deep • 35° Horizontal Drainable Blade

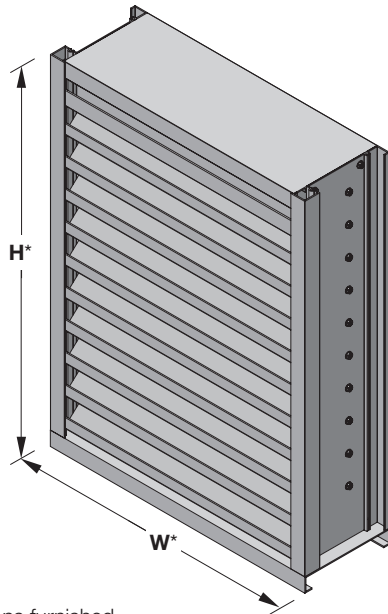

ECD-635

(standard)

*Louver dimensions furnished approximately 1/2" (13) undersize.

Ratings

Free Area: [48" × 48" (1219 × 1219) unit]: 8.0 ft² (0.75m²)
50.3%

Performance @ Beginning Point of Water Penetration

Free Area Velocity: 1,250 fpm (6.35 m/s)

Air Volume Delivered: 10,050 cfm (4.74 m³/s)

Pressure Loss: 0.33 in.wg. (82 Pa)

Velocity @ 0.15 in.wg. Pressure Loss: 874 fpm (4.44 m/s)

Design Load: 30 psf

5 year
warranty



Certified Ratings:

All-Lite certifies that the model ECD-635 shown herein is licensed to bear the AMCA seal. The ratings shown are based on test and procedures performed in accordance with AMCA Publication 511 and comply with the requirements of the AMCA Certified Ratings Program. The AMCA Certified Ratings seal applies to air performance, water penetration and wind-driven rain ratings.

The ECD-635 offers exceptional protection against wind-driven rain under the most severe conditions and is ideally suited for high wind areas or applications that are sensitive to wind-driven rain penetration. The ECD-635 incorporates horizontal blades and is available in a wide array of anodized and painted finishes including custom color matching.

Standard Construction

Material: Mill finish 6063-T5 extruded aluminum

Frame: 6" deep × 0.081" thick (152 × 2) channel

Blades: 35° × 0.081" (2) thick horizontal chevron style

Screen: 1/2" × 0.063" (12.7 × 1.6) expanded and flattened aluminum

Minimum Size: 4.5" × 7" (114 × 178)

Maximum Size:

Single section: 60" × 120" (1524 × 3048)

120" × 60" (3048 × 1524)

Multiple section: Unlimited

Options

■ Factory finish:

- High Performance Fluoropolymer
- Prime Coat
- Baked Enamel
- Clear Anodize
- Integral Color Anodize

■ Frame Options:

- 1-1/2" (38) flange frame
- Custom-size flange
- Stucco flange
- Glazing frame

■ Installation Hardware

- Clip angles
- Continuous angles

■ Alternate bird or insect screens

■ Insulated or non-insulated blank-off panels

■ Hidden Vertical Mullion

■ Filter racks

■ Hinged frame

■ Subframe

■ Head and/or sill flashing

■ Burglar bars

■ Frame closure

■ Net OD (actual size)

NOTE: Dimensions in parentheses () are millimeters.
Information is subject to change without notice or obligation.

PERFORMANCE

ECD-635

Extruded Aluminum Louver
6" deep • 35° Horizontal Drainable Blade

Free Area (ft²)

Width (Inches)

Height (Inches)	Width (Inches)																			
	4.5	12	18	24	30	36	42	48	54	60	66	72	78	84	90	96	102	108	114	120
8	0.03	0.13	0.2	0.3	0.4	0.4	0.5	0.6	0.7	0.7	0.8	0.9	1.0	1.0	1.1	1.2	1.3	1.3	1.4	1.5
12	0.1	0.3	0.5	0.6	0.8	1.0	1.1	1.3	1.5	1.7	1.8	2.0	2.2	2.3	2.5	2.7	2.9	3.0	3.2	3.4
18	0.1	0.5	0.8	1.1	1.4	1.7	2.0	2.3	2.6	2.9	3.2	3.5	3.8	4.1	4.4	4.7	5.0	5.2	5.5	5.8
24	0.2	0.8	1.2	1.7	2.1	2.6	3.0	3.5	3.9	4.4	4.8	5.3	5.7	6.2	6.6	7.1	7.5	8.0	8.4	8.9
30	0.3	1.0	1.6	2.2	2.8	3.4	4.1	4.7	5.3	5.9	6.5	7.1	7.7	8.3	8.9	9.5	10.1	10.7	11.3	12.0
36	0.3	1.3	2.0	2.8	3.6	4.3	5.1	5.8	6.6	7.4	8.1	8.9	9.6	10.4	11.2	11.9	12.7	13.4	14.2	15.0
42	0.4	1.5	2.4	3.3	4.2	5.1	6.0	6.9	7.8	8.7	9.7	10.6	11.5	12.4	13.3	14.2	15.1	16.0	16.9	17.8
48	0.4	1.7	2.8	3.8	4.9	5.9	7.0	8.0	9.1	10.1	11.2	12.2	13.3	14.3	15.4	16.4	17.5	18.5	19.6	20.6
54	0.5	2.0	3.1	4.3	5.5	6.7	7.9	9.0	10.2	11.4	12.6	13.7	14.9	16.1	17.3	18.5	19.6	20.8	22.0	23.2
60	0.6	2.2	3.6	4.9	6.2	7.6	8.9	10.2	11.6	12.9	14.2	15.6	16.9	18.2	19.6	20.9	22.2	23.6	24.9	26.2
66	0.6	2.5	4.0	5.5	6.9	8.4	9.9	11.4	12.9	14.4	15.9	17.4	18.9	20.3	21.8	23.3	24.8	26.3	27.8	29.3
72	0.7	2.7	4.4	6.0	7.6	9.3	10.9	12.6	14.2	15.8	17.5	19.1	20.7	22.4	24.0	25.7	27.3	28.9	30.6	32.2
78	0.7	3.0	4.8	6.5	8.3	10.1	11.9	13.7	15.4	17.2	19.0	20.8	22.6	24.3	26.1	27.9	29.7	31.5	33.3	35.0
84	0.8	3.3	5.2	7.2	9.1	11.1	13.0	15.0	16.9	18.9	20.9	22.8	24.8	26.7	28.7	30.6	32.6	34.5	36.5	38.4
90	0.9	3.4	5.5	7.5	9.6	11.7	13.7	15.8	17.8	19.9	22.0	24.0	26.1	28.1	30.2	32.2	34.3	36.4	38.4	40.5
96	0.9	3.7	5.9	8.1	10.3	12.5	14.8	17.0	19.2	21.4	23.6	25.8	28.0	30.3	32.5	34.7	36.9	39.1	41.3	43.5
102	1.0	3.9	6.3	8.7	11.1	13.4	15.8	18.2	20.5	22.9	25.3	27.6	30.0	32.4	34.7	37.1	39.5	41.9	44.2	46.6
108	1.0	4.2	6.7	9.2	11.7	14.2	16.8	19.3	21.8	24.3	26.8	29.3	31.8	34.4	36.9	39.4	41.9	44.4	46.9	49.5
114	1.1	4.4	7.1	9.7	12.4	15.1	17.7	20.4	23.0	25.7	28.4	31.0	33.7	36.3	39.0	41.6	44.3	47.0	49.6	52.3
120	1.2	4.6	7.4	10.2	13.0	15.8	18.6	21.3	24.1	26.9	29.7	32.5	35.3	38.0	40.8	43.6	46.4	49.2	52.0	54.7

Water Penetration

AMCA defines the beginning point of water penetration as the free area velocity at the intersection of a simple linear regression of test data and the line of 0.01 ounces of water per square foot of free area measured through a 48" x 48" louver during a 15 minute period. The AMCA water penetration test provides a method for comparing louver models and designs as to their efficiency in resisting the penetration of rainfall under specific lab conditions. We recommend that intake louvers are selected with a reasonable margin of safety below the beginning point of water penetration in order to avoid unwanted penetration during severe storm conditions.

Beginning Point of Water Penetration = 1,250 fpm

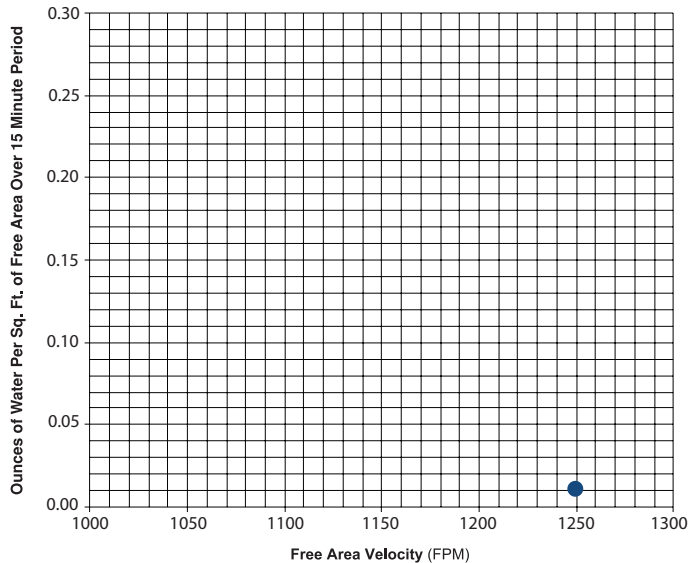

Pressure Loss

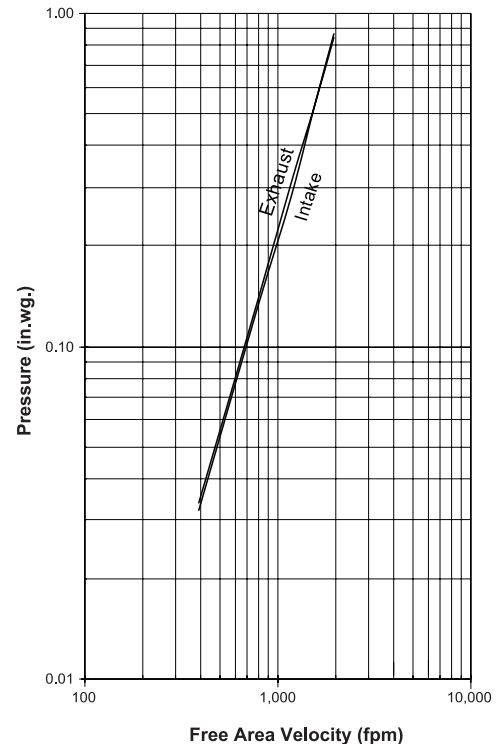

Louver Test Size = 48" x 48" (1219 x 1219)
Pressure loss tested in accordance with Figure 5.5 of AMCA Standard 500-L. Data corrected to standard air density.

PERFORMANCE

ECD-635

Extruded Aluminum Louver
6" deep • 35° Horizontal Drainable Blade

Wind Driven Rain Performance - AMCA 500L Wind-Driven Rain Test

Wind Velocity	Rainfall	Airflow cfm (m ³ /s)	Core Velocity ¹ fpm (m/s)	Free Area Velocity ² fpm (m/s)	Effectiveness Ratio	Wind-Driven Rain Penetration Class
29 mph	3 in/hr	8,473 (4.0)	787 (4.0)	1,395 (7.1)	99%	A
50 mph	8 in/hr	7,441 (3.5)	691 (3.5)	1,225 (6.2)	99.4%	A

NOTE:

1. Core area is the open area of the louver face (face area less louver frame). Core velocity is the airflow divided by core area. Test louver core area is 10.77 ft² (1 m²).

2. Free area velocity is the airflow divided by free area. Test louver free area is 6.1 ft² (0.56 m²).

Wind Driven Rain

Class	Effectiveness
A	99% and above
B	95% to 98.9%
C	80% to 94.9%
D	below 80%

Attributes

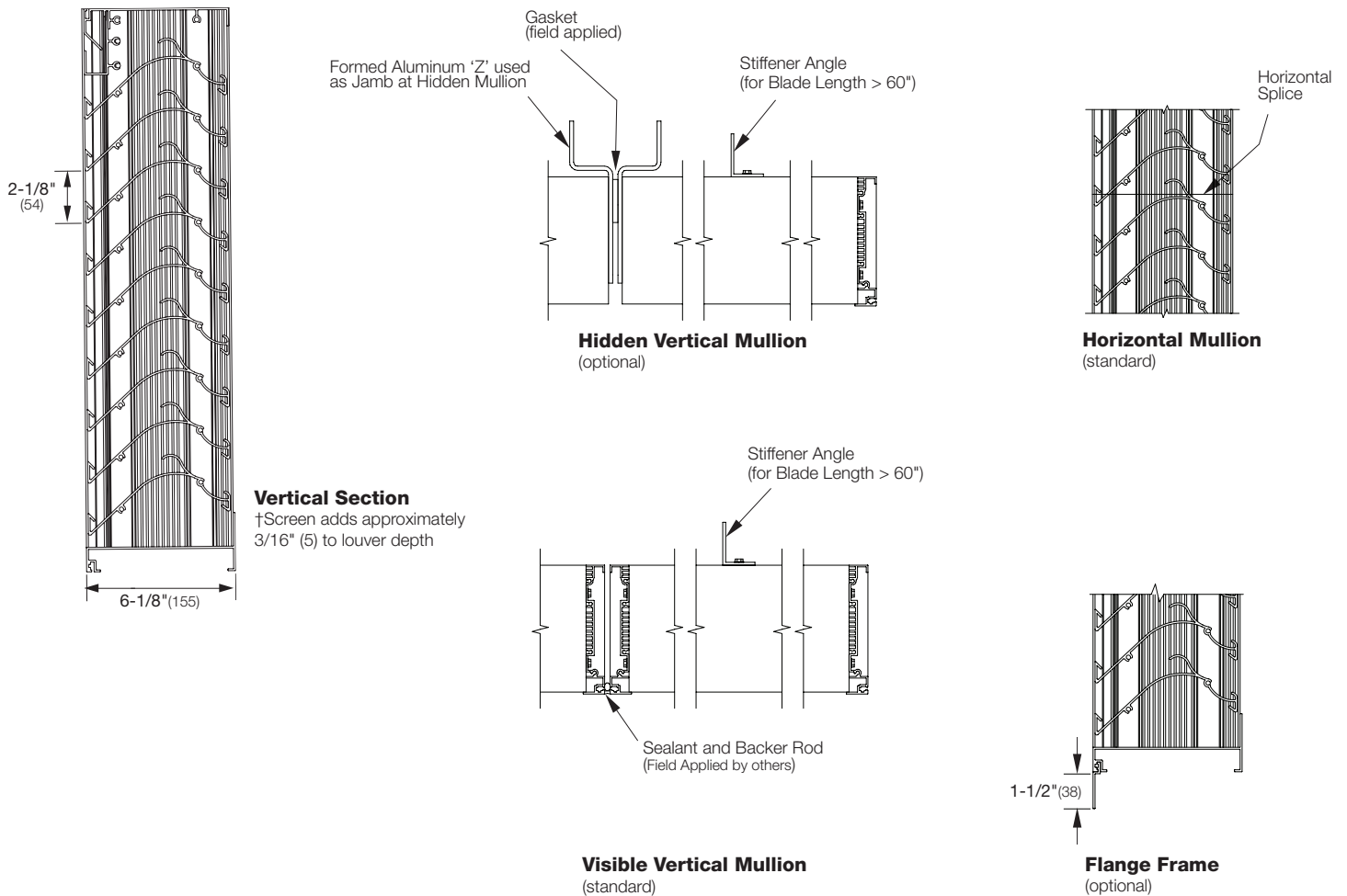

Supplemental Options

ECD-635

Extruded Aluminum Louver
6" deep • 35° Horizontal Drainable Blade

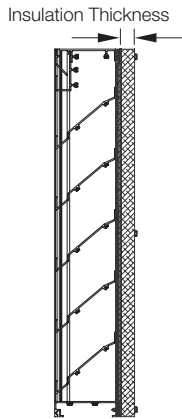

Blank-Off Options

Non-Insulated and Gasketed
1" Insulated (4.25 R-value)
2" Insulated (8.75 R-value)

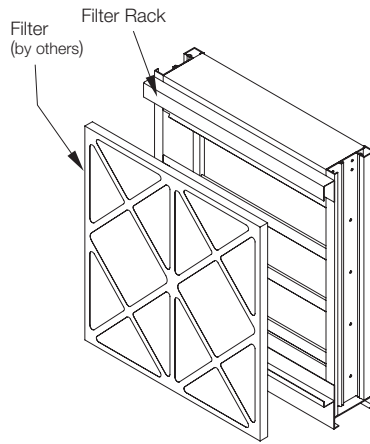

Filter Rack

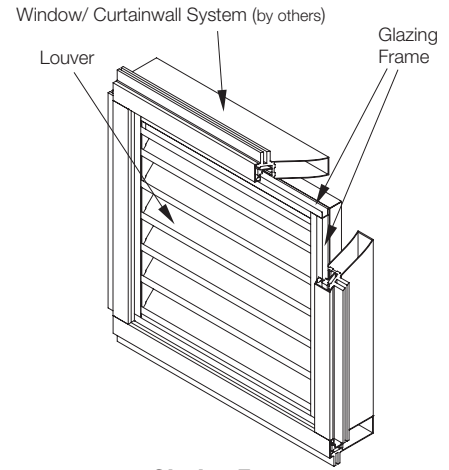

Glazing Frame

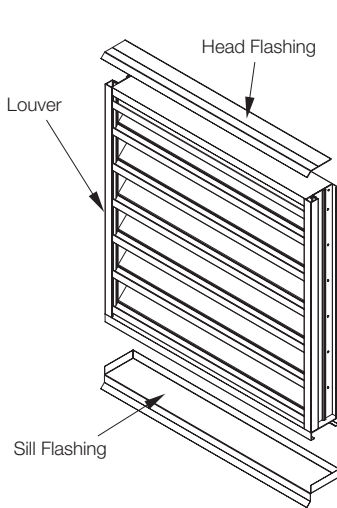

Flashing Options

Head and Sill Available

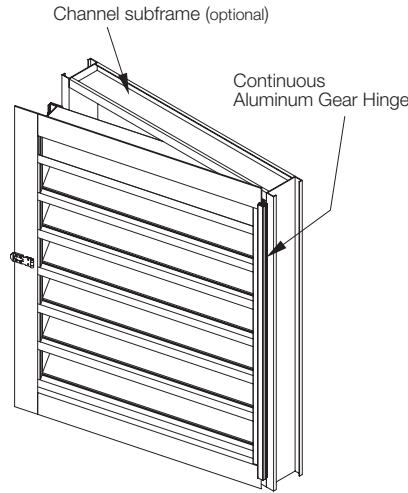

Hinge and Subframe

Right or Left Side Option Available

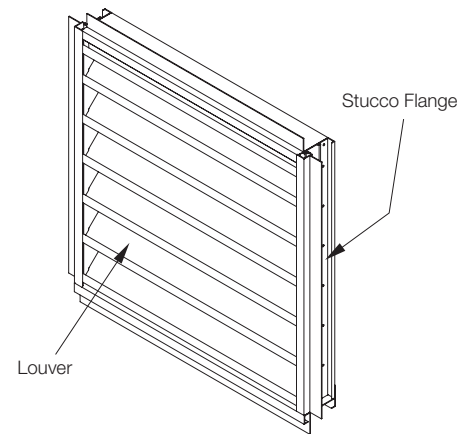

Stucco Flange