

# ALL-LITE

## ECD-245

Extruded Aluminum Louver  
2" deep • 45° Horizontal Blade

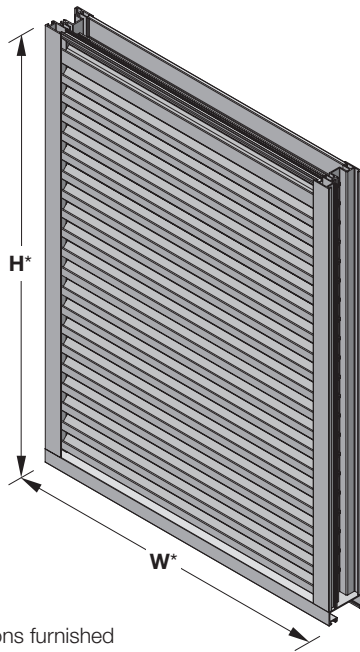

### ECD-245

(standard)

\*Louver dimensions furnished approximately 1/2" (13) undersize.

The ECD-245 offers exceptional protection against wind-driven rain under the most severe conditions. The ECD-245 incorporates horizontal blades and is available in a wide array of anodized and painted finishes including custom color matching.

## Standard Construction

**Material:** Mill finish 6063-T5 extruded aluminum

**Frame:** 2" deep × 0.060" thick (51 × 1.5) channel

**Blades:** 0.060" (1.5) thick horizontal chevron style

**Screen:** 1/2" × 0.063" (12.7 × 1.6) expanded and flattened aluminum

**Mullion:** Visible

**Minimum Size:** 4" × 5" (102 × 127)

**Maximum Size:**

Single section: 60" × 120" (1524 × 3048)

120" × 60" (3048 × 1524)

Multiple section: Unlimited

**Shipping Weight (approximate):** 3.5 lbs/ft<sup>2</sup> (17 kg/m<sup>2</sup>)

## Ratings

**Free Area:** [48" × 48" (1219 × 1219) unit]: 6.6 ft<sup>2</sup> (0.61m<sup>2</sup>)  
41.3%

**Performance @ Beginning Point of Water Penetration**

**Free Area Velocity:** 1,006 fpm (5.11 m/s)

**Air Volume Delivered:** 6,649 cfm (3.14 m<sup>3</sup>/s)

**Pressure Loss:** 0.27 in.wg. (67 Pa)

**Velocity @ 0.15 in.wg. Pressure Loss:** 760 fpm (3.86 m/s)

**5 year warranty**



### Certified Ratings:

All-Lite certifies that the model ECD-245 shown herein is licensed to bear the AMCA seal. The ratings shown are based on test and procedures performed in accordance with AMCA Publication 511 and comply with the requirements of the AMCA Certified Ratings Program. The AMCA Certified Ratings seal applies to air performance, water penetration and wind-driven rain ratings.

## Options

### ■ Factory finish:

- High Performance Fluoropolymer
- Prime Coat
- Baked Enamel
- Clear Anodize
- Integral Color Anodize

### ■ Frame Options:

- 1-1/2" (38) flange frame
- Custom-size flange
- Glazing frame
- Stucco flange

### ■ Installation Hardware

- Clip angles
- Continuous angles

### ■ Alternate bird or insect screens

### ■ Hidden mullion

### ■ Insulated or non-insulated blank-off panels

### ■ Filter racks

### ■ Hinged frame

### ■ Subframe

### ■ Head and/or sill flashing

### ■ Burglar Bars

### ■ Frame closure

### ■ Net OD (actual size)

**NOTE:** Dimensions in parentheses ( ) are millimeters.  
Information is subject to change without notice or obligation.

# PERFORMANCE

## ECD-245

Extruded Aluminum Louver  
2" deep • 45° Horizontal Blade

### Free Area (ft<sup>2</sup>)

		Width (Inches)																			
		4	12	18	24	30	36	42	48	54	60	66	72	78	84	90	96	102	108	114	120
Height (Inches)	5	0.01	0.04	0.1	0.1	0.1	0.1	0.2	0.2	0.2	0.2	0.3	0.3	0.3	0.3	0.4	0.4	0.4	0.4	0.5	0.5
	12	0.1	0.3	0.4	0.6	0.8	0.9	1.1	1.2	1.4	1.6	1.7	1.9	2.0	2.2	2.4	2.5	2.7	2.9	3.0	3.2
	18	0.1	0.5	0.7	1.0	1.3	1.6	1.9	2.1	2.4	2.7	3.0	3.2	3.5	3.8	4.1	4.4	4.6	4.9	5.2	5.5
	24	0.1	0.7	1.1	1.5	1.8	2.2	2.6	3.0	3.4	3.8	4.2	4.6	5.0	5.4	5.8	6.2	6.6	7.0	7.4	7.8
	30	0.2	0.9	1.4	1.9	2.4	2.9	3.4	3.9	4.4	5.0	5.5	6.0	6.5	7.0	7.5	8.0	8.5	9.1	9.6	10.1
	36	0.2	1.0	1.7	2.3	2.9	3.6	4.2	4.8	5.5	6.1	6.7	7.3	8.0	8.6	9.2	9.9	10.5	11.1	11.8	12.4
	42	0.2	1.2	2.0	2.7	3.5	4.2	5.0	5.7	6.5	7.2	8.0	8.7	9.5	10.2	10.9	11.7	12.4	13.2	13.9	14.7
	48	0.3	1.4	2.3	3.2	4.0	4.9	5.7	6.6	7.5	8.3	9.2	10.1	10.9	11.8	12.6	13.5	14.4	15.2	16.1	16.9
	54	0.3	1.6	2.6	3.6	4.6	5.5	6.5	7.5	8.5	9.4	10.4	11.4	12.4	13.3	14.3	15.3	16.3	17.3	18.2	19.2
	60	0.4	1.8	2.9	4.0	5.1	6.2	7.3	8.4	9.5	10.6	11.7	12.7	13.8	14.9	16.0	17.1	18.2	19.3	20.4	21.5
	66	0.4	2.0	3.2	4.4	5.6	6.8	8.1	9.3	10.5	11.7										
	72	0.4	2.2	3.5	4.9	6.2	7.5	8.8	10.1	11.5	12.8										
	78	0.5	2.4	3.8	5.3	6.7	8.2	9.6	11.0	12.5	13.9										
	84	0.5	2.6	4.1	5.7	7.3	8.8	10.4	11.9	13.5	15.0										
	90	0.6	2.8	4.5	6.1	7.8	9.5	11.1	12.8	14.5	16.1										
	96	0.6	3.0	4.8	6.5	8.3	10.1	11.9	13.7	15.5	17.2										
102	0.6	3.2	5.1	7.0	8.9	10.8	12.7	14.6	16.5	18.4											
108	0.7	3.4	5.4	7.4	9.4	11.4	13.4	15.4	17.5	19.5											
114	0.7	3.6	5.7	7.8	9.9	12.1	14.2	16.3	18.5	20.6											
120	0.7	3.7	6.0	8.2	10.5	12.7	15.0	17.2	19.5	21.7											

### Water Penetration

AMCA defines the beginning point of water penetration as the free area velocity at the intersection of a simple linear regression of test data and the line of 0.01 ounces of water per square foot of free area measured through a 48" x 48" louver during a 15 minute period. The AMCA water penetration test provides a method for comparing louver models and designs as to their efficiency in resisting the penetration of rainfall under specific lab conditions. We recommend that intake louvers are selected with a reasonable margin of safety below the beginning point of water penetration in order to avoid unwanted penetration during severe storm conditions.

**Beginning Point of Water Penetration = 1,006 fpm**

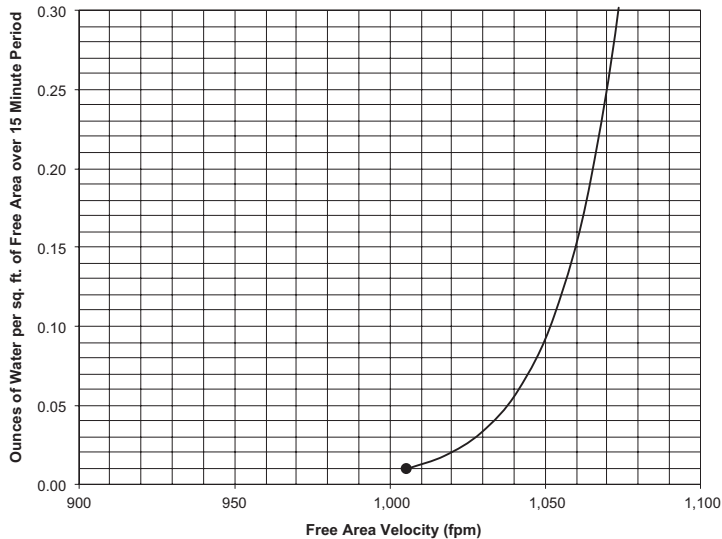

### Pressure Loss

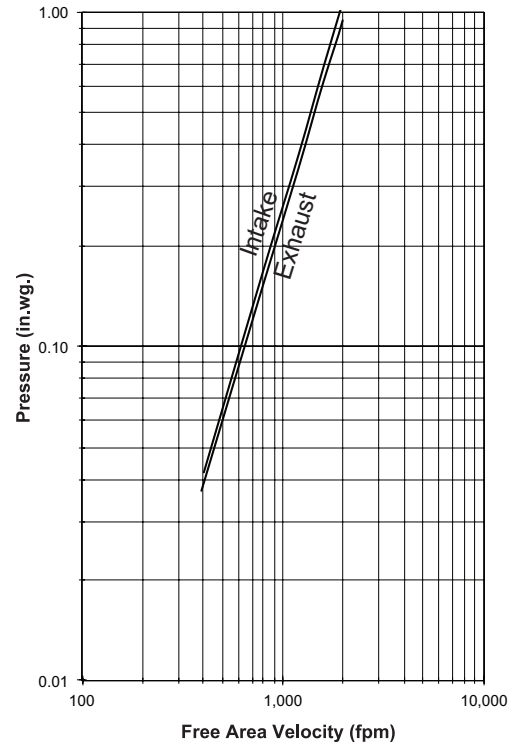

Louver Test Size = 48" x 48" (1219 x 1219)  
Pressure loss tested in accordance with Figure 5.5 of AMCA Standard 500-L. Data corrected to standard air density.

## Wind Driven Rain Performance - AMCA 500L Wind-Driven Rain Test

Wind Velocity	Rainfall	Airflow	Core Velocity <sup>1</sup>	Effectiveness Ratio	Wind-Driven Rain Penetration Class	Discharge Loss Class <sup>2</sup>
29 mph	3 in/hr	2,123 cfm	197 fpm	99%	A	3
50 mph	8 in/hr	3,011 cfm	280 fpm	95%	B	

**NOTE:**

1. Core area is the open area of the louver face (face area less louver frame). Core velocity is the airflow divided by core area. Test louver core area is 10.77 ft<sup>2</sup> (1 m<sup>2</sup>).

2. Discharge Loss Coefficient is calculated by dividing the louver's actual airflow rate by the theoretical airflow rate for an unobstructed opening. The higher the coefficient, the lower the resistance to airflow.

**Wind Driven Rain**

Class	Effectiveness
A	99% and above
B	95% to 98.9%
C	80% to 94.9%
D	below 80%

**Discharge Loss**

Class	Coefficient
1	0.4 and above
2	0.3 to 0.399
3	0.2 to 0.299
4	0.199 and below

## Attributes

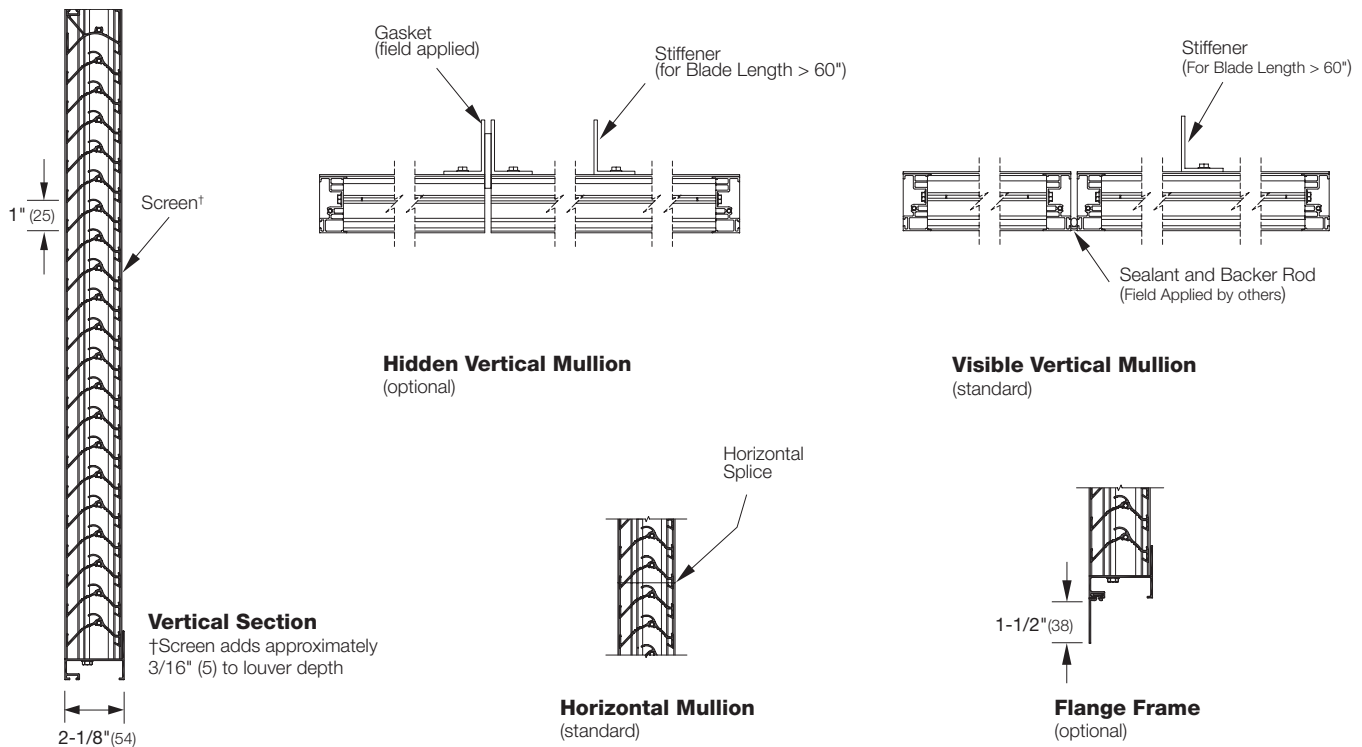

# Supplemental Options

# ECD-245

Extruded Aluminum Louver  
2" deep • 45° Horizontal Blade

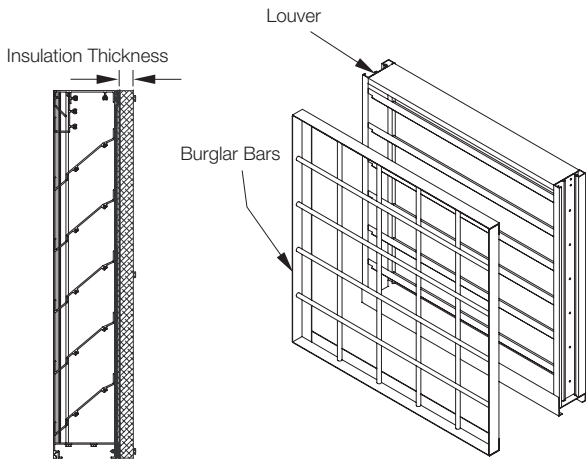

### Blank-Off Options

Non-Insulated and Gasketed  
1" Insulated (4.25 R-value)  
2" Insulated (8.75 R-value)

### Burglar Bars

Shipped Loose or Mounted

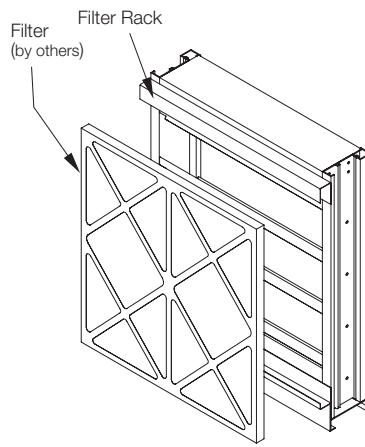

### Filter Rack

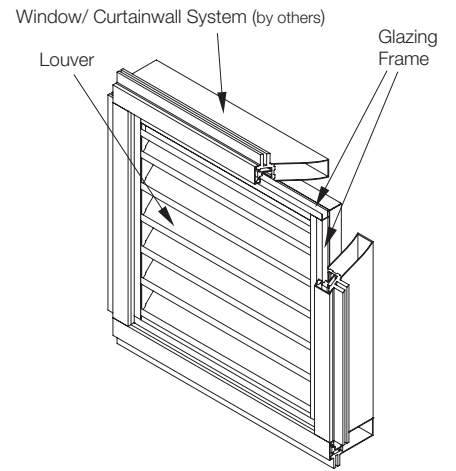

### Glazing Frame

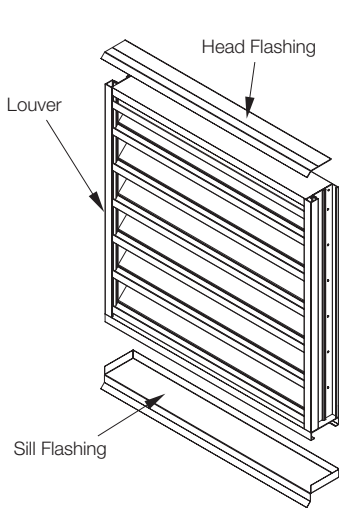

### Flashing Options

Head and Sill Available

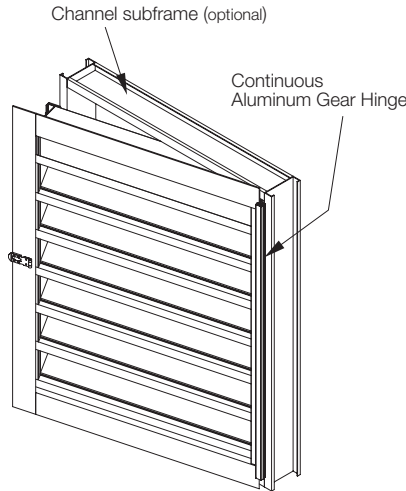

### Hinge and Subframe

Right or Left Side Option Available

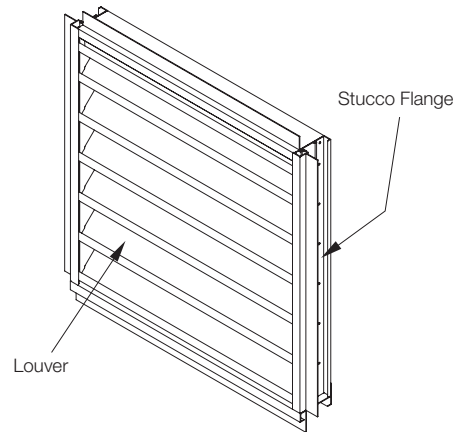

### Stucco Flange

3/4" (19) Standard Stucco Depth