

IMPORTANT: READ ALL INSTRUCTIONS BEFORE PROCEEDING WITH INSTALLATION

General

The following guidelines provide basic assembly and installation instructions for ECV-645-MD extruded aluminum louvers mounting to concrete masonry (CMU) building conditions. The ECV-645-MD is designed to withstand severe weather effects typically associated with hurricanes, and has been tested for resistance to impacts, cyclic fatigue, and static pressures up to 150 psf.

1. For additional details, refer to the product drawing package posted at www.alllite.com as well as any job-specific submittal drawings when provided.
2. Carefully lift louver sections by the frames using multiple lifting points as necessary to avoid distortion, racking, or other damage. **Do not apply excessive force to a single blade, and NEVER LIFT UNITS BY LOUVER BLADES.** Take necessary precautions to prevent marring the louver finish.
3. While installation is underway and before louver sections are permanently fastened in place, All-Lite recommends that the installer employ temporary straps or bracing (by others) to prevent units from shifting unexpectedly.
4. All gaskets and caulk are supplied by others.

Preparation

Louvers and Hardware:

1. Locate all crates, boxes, cartons, etc.
2. Remove louvers from packaging, inspect for damage, confirm quantities and sizes with packing list, and organize parts in order of installation. To verify installation hardware, refer to Table 1. Installation hardware will typically be shipped in a separate box.
3. Notify your All-Lite representative immediately of any shortages or shipping damage.

Openings:

1. Inspect openings for damage, repair as needed, and remove any obstructions or debris.
2. Prior to installation, verify that openings are square and plumb and that the louvers will fit properly.

Sill Flashing

1. Locate the sill flashing (by others, or optional by All-Lite). Closed-end sill flashing is recommended for all non-sleeved ECV-645-MD installations.
2. Confirm that the sill of the opening and the underside of the flashing are clean and free of all debris.

3. Apply caulk to the sill of the opening and firmly set the sill flashing in the caulk. See Figure 1.1.
 - a. For wider openings, multiple pieces of flashing may be necessary in order to cover the entire width. When this occurs, caulk at all overlapping joints and firmly set. See Figure 1.2.
 - b. Closed end flashing pieces (if supplied by Pottorff) will include extra length on each end which must be cut, and manually bent into place to close off the sill flashing ends. Carefully bend up the end tabs and thoroughly caulk the corner seams. See figure 1.3.

Table 1: Installation Hardware, CMU Building Condition





Part	Description		
A-1	Continuous Angle (3 1/2" x 1 1/2" x 1/8" x Varying Length)		Included
A-3	Shelf Angle (6" x 4" x 3/8" Varying Length)		Included
F-4	1/4" x 1" Hex-Head Self Drilling Machine Screw		Included
F-5	3/8 x 4" Hilti Kwik HUS-EZ Screw Anchor		Supplied by Others
F-6	3/8" x 3 1/2" Hilti Kwik HUS-EZ Screw Anchor		Supplied by Others

Figure 1.1: Sill Flashing Vertical Section

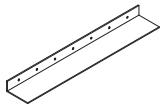
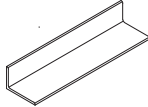
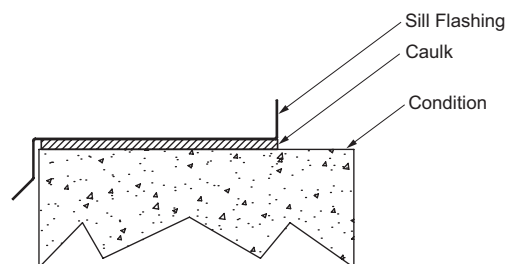
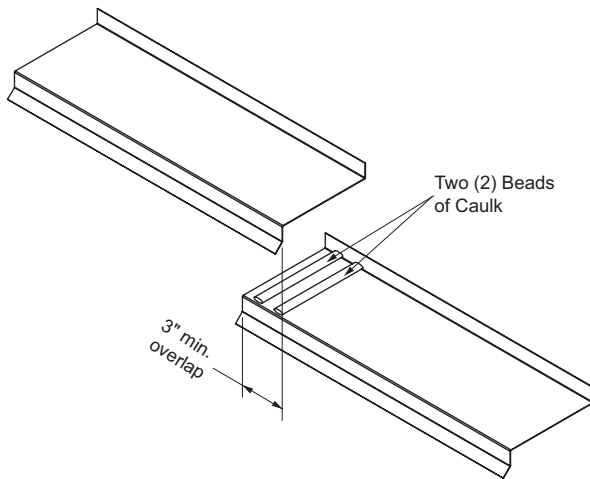
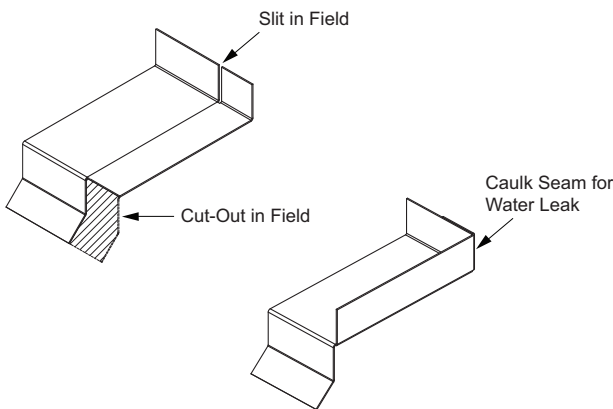

Figure 1.2: Sill Flashing Assembly

Figure 1.3: Closed End Sill Flashing

Single Section Louver Installation

- Determine the thickness of the building wall. If overall wall depth (including any exterior facade) is less than 9 5/8", use the configuration shown in Figure 3 for a tension-type connection. Otherwise, refer to Figure 2 for a shear-type connection.

Tension Connections (Figure 3):

- Locate the 6" x 4" secondary angles (A-3) and drill a series of 7/16"-diameter clearance holes for anchors in each length of angle.
 - Place the holes in the 6" leg of the angle, along a line located 4" from the angle corner.
 - Drill one hole 2" from each end, and then locate the remaining holes no more than 4" apart.
- Determine the placement of the shelf angles along the top and bottom of the opening, referring to Figure 3. The 6" surface of the angle will sit against the rear face of the concrete wall, while the 4" angle surface should be flush with the top or bottom of the opening.
- Using the hole pattern in the shelf angles as a guide, drill 3/8"-diameter holes into the rear face of the masonry above and below the wall opening. Holes should be drilled at least 3 7/8" deep. Adjust hole locations as necessary to avoid placing any anchor closer than 1 1/4" to a vertical joint ("head joint") between masonry units.

- After cleaning any dust or loose material from the holes, use 3/8" x 4" Hilti Kwik HUS-EZ screw anchors (F-5) to fasten the shelf angles to the wall. Anchors will run through the clearance holes in the angles into the anchor holes in the masonry. Tighten anchors to the correct installation torque specified by Hilti.
- Lift the louver section up and place it into the opening as shown in Figure 3. The front of the louver should be flush with the exterior surface of the wall.
- As necessary, shim around the perimeter to level the louver and to maintain an approximate 1/4" clearance between the louver frame and the edges of the opening (shims are by others).
- Locate the 1 1/2" x 3 1/2" continuous angles (A-1) and fasten them to the back of the louver frame using 1/4-14 x 1" self-drilling screws (F-4) inserted through the existing clearance holes in the angles. The 3 1/2" leg of each angle should sit against the top or bottom surface of the opening.
- Fasten the 1 1/2" x 3 1/2" continuous angles to the 6" x 4" shelf angles using 1/4-14 x 1" self-drilling screws spaced no more than 5" apart and 2 1/2" from each end.
 - Drill clearance holes in the 1 1/2" x 3 1/2" continuous angles.
 - As necessary, drill pilot holes through the 6" x 4" shelf angles. To ensure proper thread engagement pilot hole diameters must not exceed 3/16".
- Finish by installing backer rod and caulk around the perimeter of the opening. **To allow for drainage, do not caulk the front gap between louvers and sill flashing.**

Shear Connections (Figure 2):

- For shear connections, the 6" x 4" shelf angles (A-3) may be discarded. Begin by locating the 1 1/2" x 3 1/2" continuous angles (A-1), and determine their placement along the top and bottom of the opening, using Figure 2 as a reference. The continuous angles will sit against the rear side of the louver, so they should be placed 6 1/8" behind the exterior face of the wall. (6" behind the exterior face for flanged louvers). If sill flashing has been installed, the angles will be immediately behind the flashing.
- Drill a series of 7/16"-diameter clearance holes for anchors in each length of angle.
 - Each angle will arrive with one side pre-drilled with clearance holes for fasteners. Anchor clearance holes should be drilled in the opposite leg of the angle (the side without pre-drilled holes).
 - Be careful not to locate any anchor closer than 2 5/8" to the rear edge of the masonry. The anchors should also be at least 3" from the front edge of the blocks.
 - Drill one hole 3" from each end and then locate the remaining holes no more than 6" apart.
- Using the hole pattern in the continuous angles as a guide, drill 3/8"-diameter holes into the masonry above and below the wall opening. Holes should be drilled at least 3 5/8" deep. Again, be careful to maintain the required minimum distances to the edges of the masonry, as shown in Figure 2.

14. After cleaning any dust or loose material from the holes, use 3/8" x 3 1/2" Hilti Kwik HUS-EZ screw anchors (F-6) to fasten the continuous angles to the top and bottom surfaces of the opening. Anchors will run through the clearance holes in the angles into the anchor holes in the masonry. Tighten anchors to the correct installation torque specified by Hilti.
15. Lift the louver section up and place it into the opening as shown in Figure 2. The back of the louver should sit directly against the continuous angles.
16. As necessary, shim around the perimeter to level the louver and to maintain an approximate 1/4" clearance between the louver frame and the edges of the opening (shims are by others).
17. Attach the louver section to the continuous angles using 1/4-14 x 1" self-drilling screws (F-4) running through the existing clearance holes in the angles.
18. Finish by installing backer rod and caulk around the perimeter of the louver, as required. **To allow for drainage, do not caulk the front gap between louvers and sill flashing.**

Multiple Section Louver Installation

1. Determine the thickness of the building wall. If overall wall depth is less than 9 5/8", use the configuration shown in Figure 3 for a tension-type connection. Otherwise, refer to Figure 2 for a shear-type connection.
2. Moving from left to right, follow steps 2-9 or steps 11-17 from "Single Section Louver Installation," as applicable, to install each louver section within the opening.
 - a. For louvers ordered with an optional 1 1/2" flange, different louver sections are of distinct construction and are not interchangeable. The Left End section will have flange on the left side, the Right End section will have flange on the right side, and any Center sections (if present) will be flanged on the top and bottom only.
 - b. For non-flanged louvers, different sections within an opening are completely interchangeable and may be installed in any order desired.
 - c. Shim as necessary to maintain an approximate 1/4" clearance between the louver frames and the wall condition, and approximately 1/4" between sections (shims by others).
3. Finish by installing backer rod and caulk in the following locations:
 - a. All vertical joints between sections.
 - b. Around the perimeter of the opening.

To allow for drainage, do not caulk the front gap between louvers and sill flashing.

Figure 2: Standard Installation to Concrete, Shear Connection

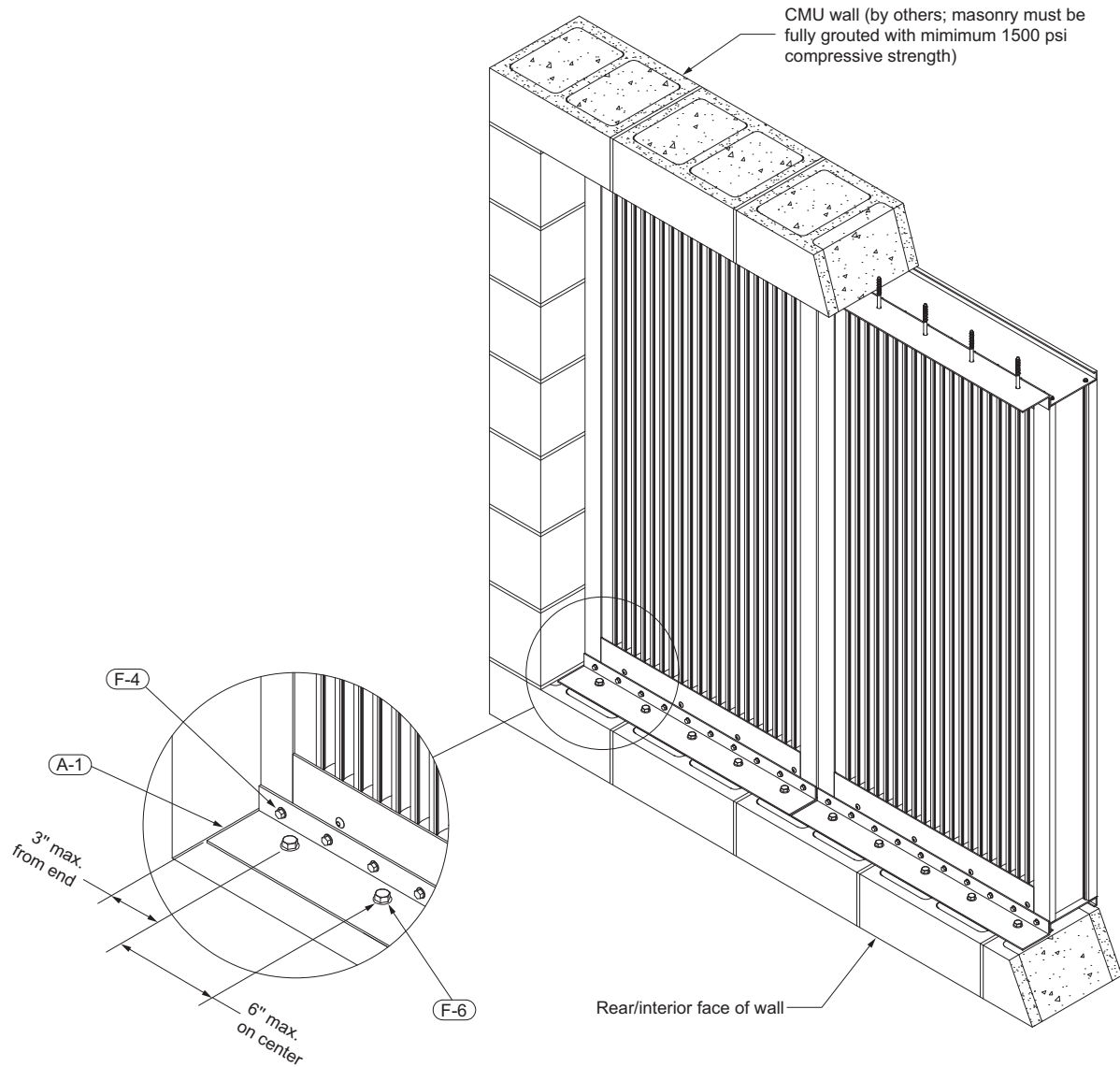

Section Detail at Top & Bottom Connections

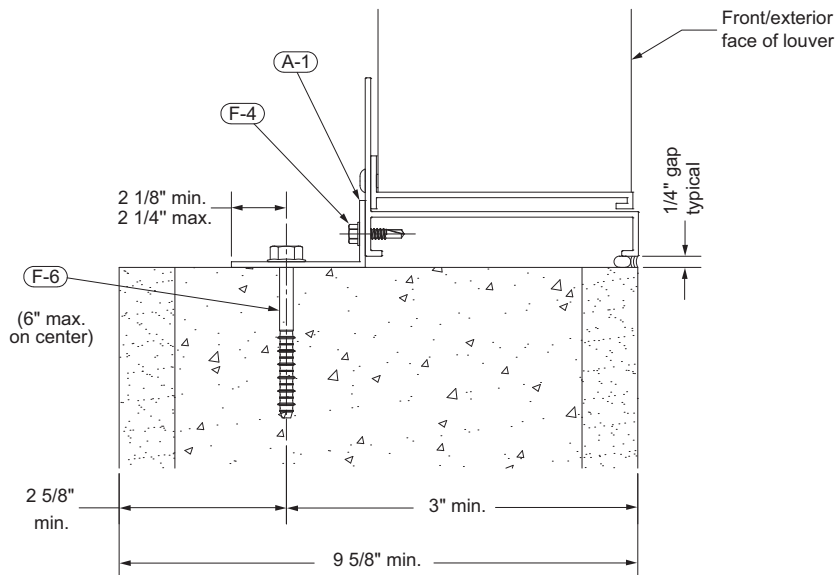

ECV-645-MD Installation Instructions, CMU Building Condition **MI-54184-2** Rev. C. (4/15) February 2020

Figure 3: Standard Installation to Concrete, Tension Connection

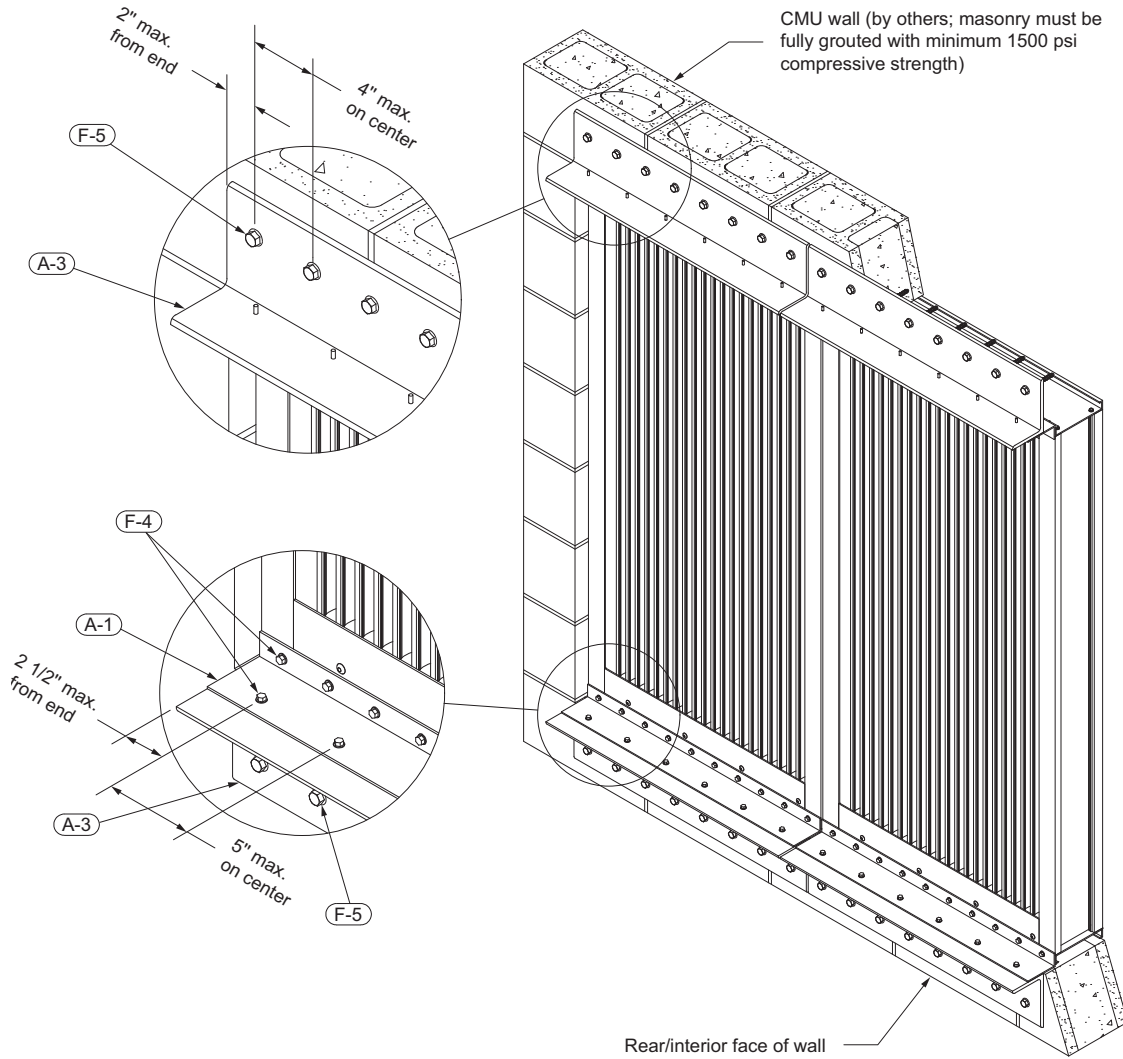

Section Detail at Top & Bottom Connections

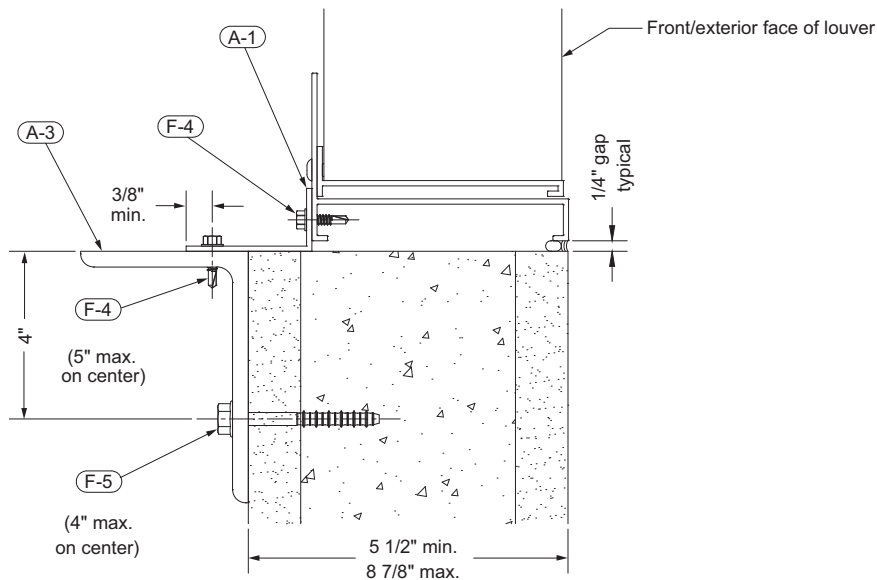

ECV-645-MD Installation Instructions, CMU Building Condition **M-54184-2** Rev. C. (5/5) February 2020