

IMPORTANT: READ ALL INSTRUCTIONS BEFORE PROCEEDING WITH INSTALLATION

General

The following guidelines provide basic assembly and installation instructions for ECD-545-MD extruded aluminum louvers mounting to grout-filled concrete masonry (CMU) building conditions. The ECD-545-MD is designed to withstand severe weather effects typically associated with hurricanes, and has been tested for resistance to impacts, cyclic fatigue, and static pressures up to 150 psf.

1. For additional details, refer to the product drawing package posted at www.alllite.com as well as any job-specific submittal drawings when provided.
2. Carefully lift louver sections by the frames using multiple lifting points as necessary to avoid distortion, racking, or other damage. **Do not apply excessive force to a single point, and NEVER LIFT UNITS BY LOUVER BLADES.** Take necessary precautions to prevent marring the louver finish.
3. All gaskets and caulk are supplied by others.

Preparation

Louvers and Hardware

1. Locate all crates, boxes, cartons, etc.
2. Remove louvers from packaging, inspect for damage, confirm quantities and sizes with packing list and organize parts in order of installation. To verify installation hardware quantities, refer to Table 1. Installation hardware will typically be shipped in a separate box.
3. Notify your All-Lite representative immediately of any shortages or shipping damage.

Openings

1. Inspect openings for damage, repair as needed and remove any obstructions or debris.
2. Prior to installation, verify that openings are square and plumb and that the louvers will fit properly.

Sill Flashing

1. Locate the sill flashing (by others, or optional by All-Lite). Closed-end sill flashing is recommended for all non-sleeved ECD-545-MD installations.
2. Confirm that the bottom of the opening and the underside of the flashing are clean and free of all debris.
3. Apply caulk to the bottom of the opening and firmly set the sill flashing in the caulk. See Figure 1.1.
 - a. For wider openings, multiple pieces of flashing may be necessary in order to cover the entire width. When this occurs, caulk at all overlapping joints and firmly set. See Figure 1.2.
 - b. Closed end flashing pieces (if supplied by All-Lite) will include extra length on each end which must be cut, and manually bent into place to close off the sill flashing ends. Carefully bend up the end tabs and thoroughly caulk the corner seams. See figure 1.3

Figure 1.1 Sill Flashing Vertical Section

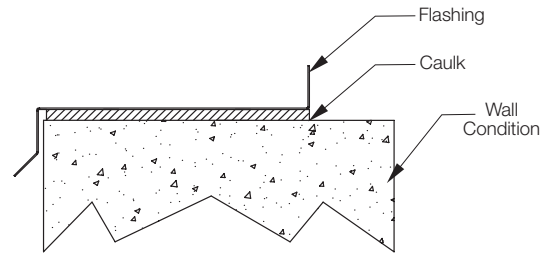

Figure 1.2 Sill Flashing Assembly

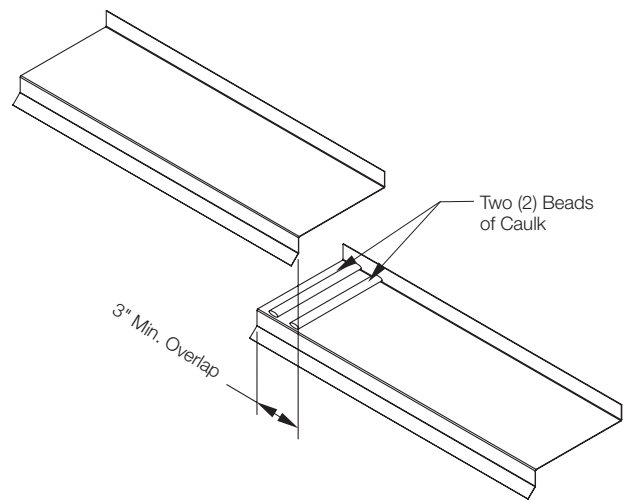
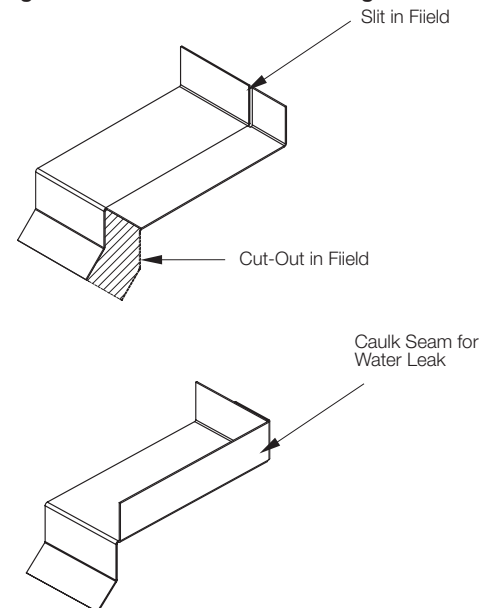

Figure 1.3 Closed End Sill Flashing







Installation Details

ECD-545-MD HURRICANE LOUVER

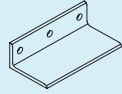
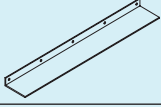
Installation Instructions - CMU Building Condition

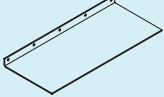
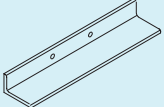
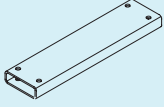
Table 1: Installation Hardware

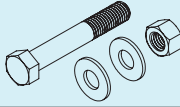
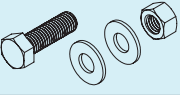
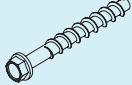
Part	Description		
A-1	Mullion Clip Angle (5" x 3" x 3/8" x 10"-Long)		Included for multi-wide assemblies only
A-2	Continuous Angle (3" x 1" x 1/8" x Varying Length)		Included
A-4	Jamb Support Angle (3" x 2" x 1/4" x Varying Length)		Included for multi-wide assemblies only
A-8	Mullion Attachment Angle (7" x 1" x 1/8" x Varying Length)		Included for multi-wide assemblies only
A-10	Mullion Shelf Angle (2" x 6" x 1/8" x Varying Length)		Included for multi-wide assemblies only
S-1	Mullion Support Tube (6" x 2" x 1/4" x Varying Length)		Included for multi-wide assemblies only
F-4	#12-14 x 1" Hex-Head Self-Drilling Machine Screw		Included
F-5	5/8-11 x 4" Hex Bolt with Nut and two (2) Flat Washers		Included for multi-wide assemblies only
F-6	5/8-11 x 2" Hex Bolt with Nut and two (2) Flat Washers		Included for multi-wide assemblies only
F-7	3/8" x 4" DeWalt Screw-Bolt+		Supplied by Others

Single Section Louver Installation

- Begin by locating the 3" x 1" continuous angles (A-2), and determine their placement along the sides of the opening using Figure 2 as a reference. The continuous angles will attach to the rear side of the louver, so they should be recessed 5" behind the exterior face of the wall. Leave approximately 4-1/4" from the lower end of each angle to the bottom of the opening.
- Drill a series of 7/16"- diameter clearance holes for anchors in each length of angle.
 - Each angle will arrive with one side pre-drilled with clearance holes for #12 fasteners. Anchor clearance holes should be field-drilled in the opposite leg of the angle (the side without pre-drilled holes).
 - Be careful not to locate any anchor closer than 1-1/2" to the edge of the masonry.
 - Drill one hole 2-1/2" from each end and then locate the remaining holes no more than the max spacing listed in Table 2 for F-7 along a line between the two holes.
- Using the anchor hole pattern in the continuous angles as a guide, drill 3/8"- diameter holes into the sides of the wall opening. Holes should be drilled at least 4-1/4" deep. Again, be careful to maintain at least 1-1/2" from anchor locations to any edge of the masonry.
- After cleaning any dust or loose material from the holes, use 3/8" x 4" DeWalt Screw-Bolt+ (F-7) to fasten the continuous angles to the wall. Anchors will run through the clearance holes in the angles into the anchor holes in the masonry. Tighten anchors to the correct installation torque specified by DeWalt.
- Lift the louver up and place it into the opening as shown in Figure 2. The back of the louver should sit directly against the continuous angles.
- As necessary, shim around the perimeter to level the louver and to maintain an approximate 1/4" clearance between the louver frame and the edges of the opening (shims are by others).
- Attach the louver section to the continuous angles using #12-14 x 1" self-drilling screws (F-4) running through the existing clearance holes in the angles.
- Finish by installing backer rod and caulk around the perimeter of the louver, as required.

Table 2: Max Anchor Spacing

Part	Louver Width	
	≤ 60"	> 60"
F-4	10"	9"
F-7	5"	4"

Installation Details

ECD-545-MD HURRICANE LOUVER Installation Instructions - CMU Building Condition

Multiple Section Louver Installation

1. Follow steps 1- 4 from "Single Section Louver Installation" to install continuous angles (A-2) along the sides of the opening.
2. Locate the mullion clip angles (A-1) and drill an 11/16"- diameter hole in the 5" leg of each angle.
 - a. Use Figure 3 as a guide for hole placement.
 - b. Note that Dimension 'A' in Figure 3 is variable and depends on the overall thickness of the wall into which the louver will be installed. To find Dimension A, measure the wall thickness and subtract 3-3/4".
 - c. For example, if the building wall is 8" thick, Dimension A should be 4-1/4".
3. Locate the mullion shelf angles (A-3) and drill a series of six (6) 7/16"- diameter holes in each shelf angle.
 - a. Place the holes in the 5" leg of the angle, along a line located 2" from the angle corner.
 - b. Drill one hole approximately 2" from the end of the angle and then space the remaining holes 4" apart.
4. Determine the placement of shelf angles on the rear of the wall above and below the opening.
 - a. Each shelf angle will be centered on a vertical joint between louver sections.
 - b. The 3" leg of the shelf angle should be flush with the edge of the opening.
5. Using the shelf angle hole pattern as a template, drill 3/8"-diameter holes into the rear face of the masonry wall. Holes should be drilled at least 4" deep.
6. After cleaning any dust or loose material from the holes, use 3/8" x 4" DeWalt Screw-Bolt+ anchors (F-7) to fasten the shelf angles to the rear face of the wall. Anchors will run through the clearance holes in the angles into the anchor holes in the masonry. Tighten anchors to the correct installation torque specified by DeWalt.
7. Locate each mullion support tube (S-1), and fasten pairs of mullion clip angles (A-1) to the ends of the tube using 5/8" x 4" bolts, nuts, and flat washers (F-5) as shown in Figure 3. For an easier fit during installation, fully tighten only the bolts at the bottom end of the tube. Loosely connect the bolts at the top, but wait to tighten them until the mullion tube has been placed in its final location.
8. Lift the mullion tube (with attached clip angles) into place, and use 5/8" x 2" bolts, nuts, and flat washers (F-6) to fasten the clip angles to the shelf angles above and below the opening. Line up the field-drilled hole in each clip angle with the corresponding hole in the shelf angle.
9. Lay out the louver sections face down in the approximate order in which they will be positioned within the opening. At mullion joints between adjacent sections, use #12-14 x 1" self-drilling screws (F-4) to install mullion attachment angles (A-8) to the back of the louver frame jambs. Use Figures 4 and 5 as a reference.
 - a. Align the edge of the 1" angle leg with the edge of the frame jamb. The bottom end of the angle will sit directly against the top of the frame sill.
 - b. Screws will run through the existing clearance holes in the mullion attachment angle into the louver frame.
10. Lift each louver section up and fasten it in place within the opening as shown in Figure 2. The front of the louver should be flush with the exterior surface of the wall.
 - a. Shim as necessary to level the louver sections and to maintain an approximate 1/4" clearance between the louver frames and the edges of the opening, and approximately 1/4" between sections (shims by others).
 - b. Along the sides of the opening, fasten the continuous angles to the louver jambs using #12-14 x 1" self-drilling screws (F-4). Screws will run through the existing clearance holes in the continuous angles into the louver frame.
 - c. At each mullion between adjacent sections, fasten the mullion attachment angles to the sides of the mullion tube using #12-14 x 1" self-drilling screws (F-4), as shown in Figure 5.
 - i. Screws should be located no more than the max spacing listed in Table 2, 6" from each end of the angle, and at least 2-1/2" from any edge.
 - ii. Drill pilot holes as necessary. To ensure proper thread engagement, pilot hole diameters must not exceed 3/16".
11. Finish by installing backer rod and caulk in the following locations:
 - a. All vertical joints between sections
 - b. Around the perimeter of the opening

Installation Details

ECD-545-MD HURRICANE LOUVER

Installation Instructions - CMU Building Condition

Figure 2: CMU Installation

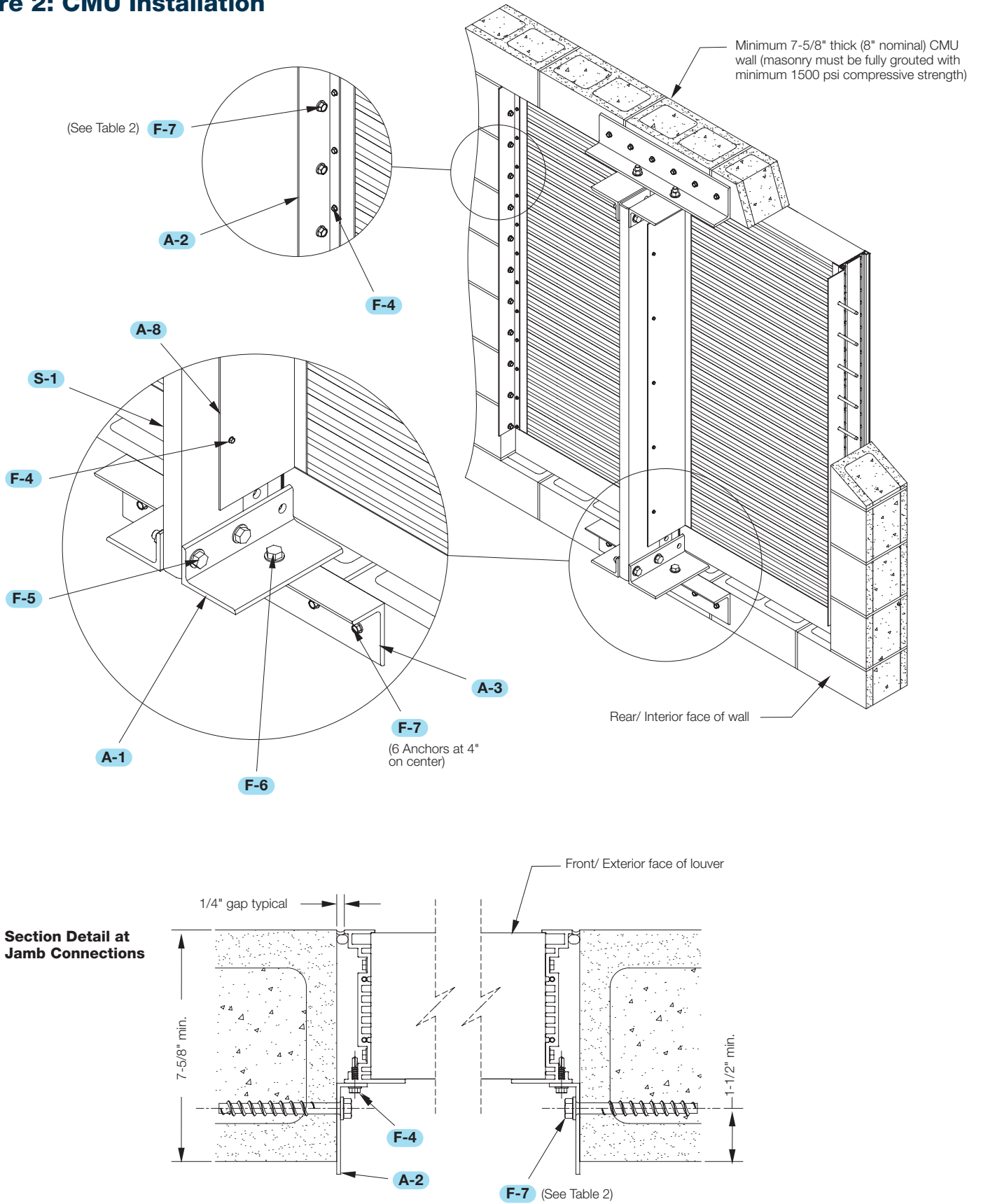

Installation Details

ECD-545-MD HURRICANE LOUVER

Installation Instructions - CMU Building Condition

Figure 3: Mullion Support Assembly

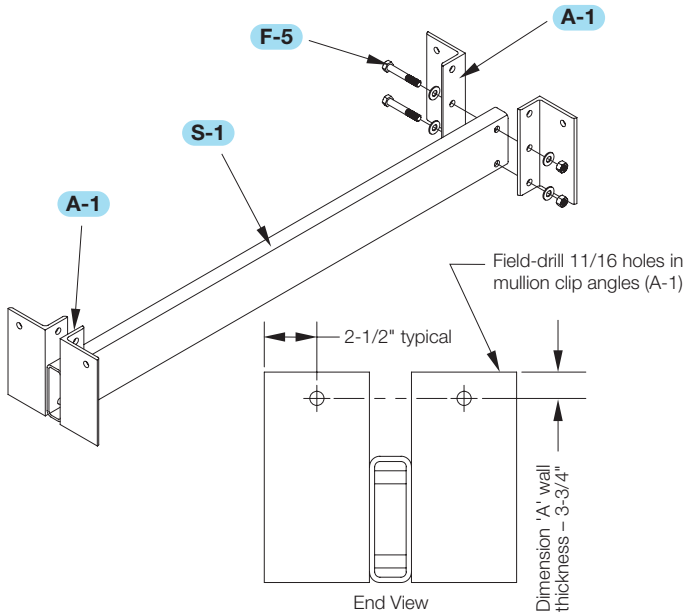

Figure 5: Mullion Section Detail

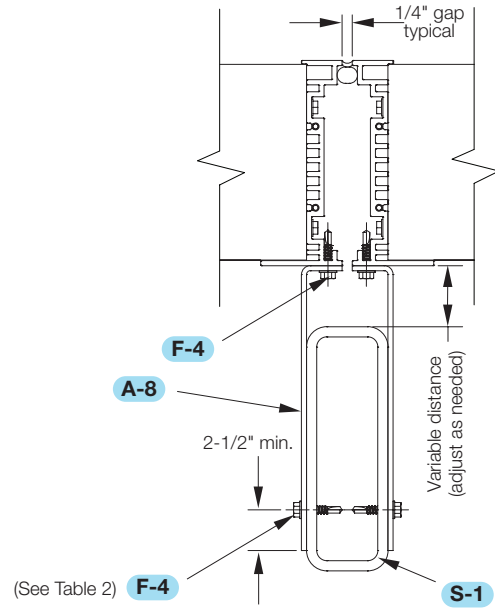

Figure 4: Installation Mullion Attachment Angles

