

### General

The following guidelines provide basic assembly and installation instructions for standard All-lite extruded aluminum stationary blade louvers. All-lite standard louvers are designed to resist a 30 psf wind load.

1. Consult with the Engineer of record for the size, type, and quantity of anchors required to secure the louver to the surrounding condition.
2. Refer to job-specific submittal drawings for additional details when provided.
3. Carefully lift louver sections by their frames or support members using multiple lifting points if necessary to avoid distortion, racking or damage. **Do not apply excessive force to a single point and NEVER LIFT UNITS BY LOUVER BLADES.** Take necessary precautions to prevent marring the louver finish.
4. Caulk and anchors are by others. Proper isolation (by others) is recommended between aluminum louver components and steel building conditions to prevent corrosion.

### Preparation

#### Louvers and Hardware

1. Locate all crates, boxes, cartons, etc.
2. Remove louvers from packaging, inspect for damage, confirm quantities and sizes with packing list, and organize parts in order of installation. If installation hardware was ordered it will typically be in a separate box.
3. Notify your All-lite representative immediately of any shortages or shipping damage.

#### Openings

1. Inspect openings for damage, repair as needed, and remove obstructions and debris as required.
2. Verify that openings are square, plumb, and that the louvers will fit properly prior to installation.

### Sill Flashing (if applicable)

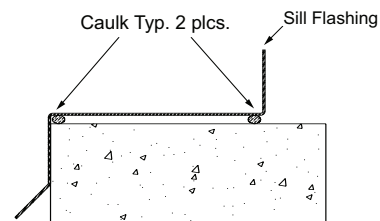
1. Locate all sill flashing (by others or optional by All-lite). Sill flashing is recommended for all multiple section wide louvers.
2. Confirm that the sill of the opening and the underside of the sill flashing are clean and free of all debris.
3. Apply caulk to the sill of the opening and firmly set the sill flashing in the caulk. See fig. 1.1.
  - a. Caulk multiple section sill flashing at the overlapping joint(s) and firmly set. See fig. 1.2.
  - b. When sill flashing end caps are required, caulk the underside of the end cap and firmly set over the top of the sill flashing taking care to butt the edge of the vertical leg snugly against the edge of the vertical leg of the sill flashing and adequately caulk the joining vertical seam. See fig. 1.2.

### Single Section Louver Installation

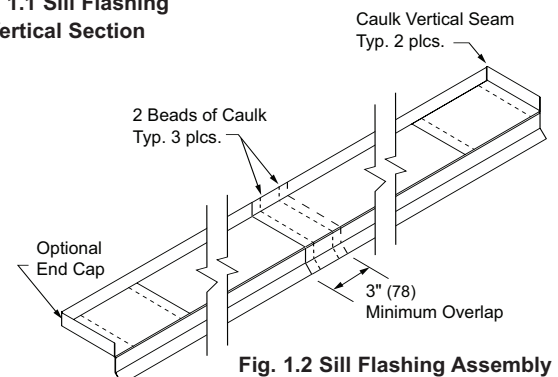
1. Locate and anchor clip angles as required to establish proper louver depth and position. See fig. 2.1 for required spacing. (Clip angles are by others or optional by All-lite).
2. Place the louver section into the opening.
3. Shim around the perimeter of the louver to maintain the proper sealant joint clearance and to level the louver. (Shims are by others).
4. When the louver is level and in the proper position, fasten louver frame to clip angles with minimum #12 screws (by others).
5. Install backer rod and caulk around the entire perimeter of the louver, as required. **Do not caulk between louver and sill flashing to allow for drainage.**

### Multiple Section Louver Installation

1. Locate and anchor clip angles as shown on following page. (Clip angles are by others or optional by All-lite).
2. Install the lower left section (as viewed from the exterior) following steps 2-4 above. If multiple sections high, install the upper left section(s) following steps 2-4 above. Install Jamb Splice and Stiffener Splice when required. See fig. 3.4 and 3.5.
3. For visible mullions, install I-mullion on right hand jamb (as viewed from the exterior). See fig. 3.2.
4. For hidden mullions, install gasket or sealant (by others) between mating stiffener angles. See fig. 3.3.
5. Install backer rod and caulk around the entire perimeter of the louver, as required. **Do not caulk between louver and sill flashing to allow for drainage.**

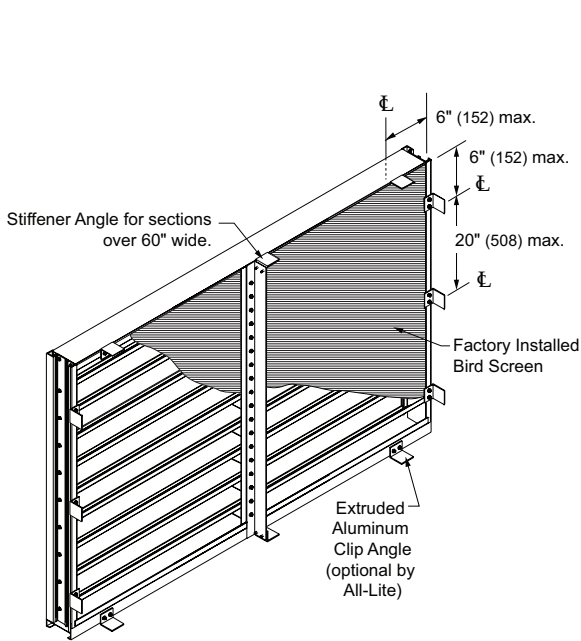


**Fig. 1.1 Sill Flashing  
Vertical Section**

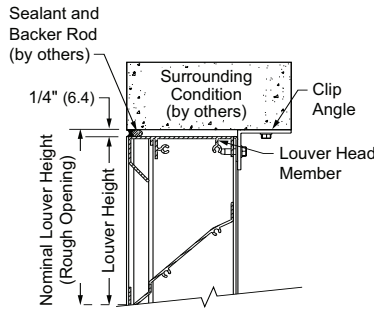


**Fig. 1.2 Sill Flashing Assembly**

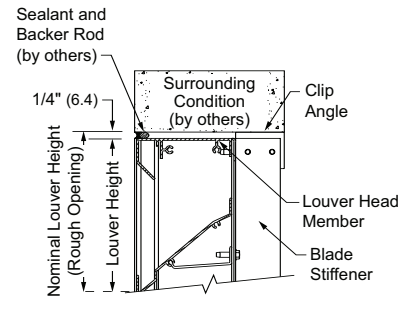
**Single Section Louver Installation**



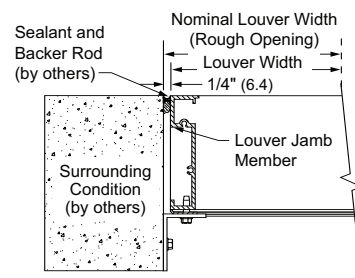
**Fig. 2.1 Clip Angle - Single Section Louver**



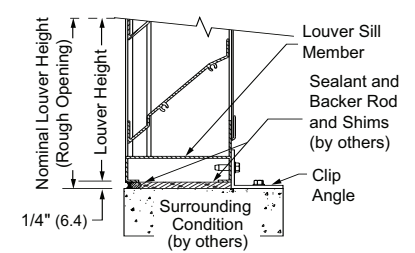
**Fig. 2.2 Head**



**Fig. 2.3 Stiffener**

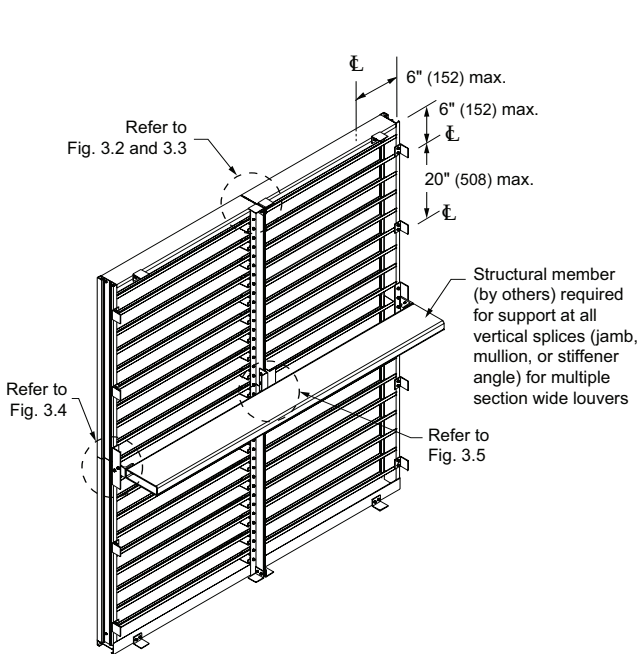


**Fig. 2.4 Jamb**

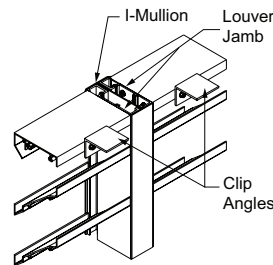


**Fig. 2.5 Sill**

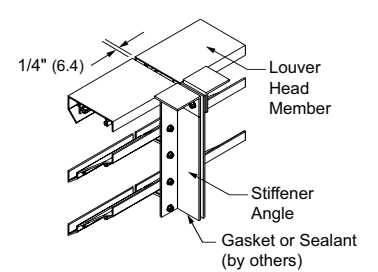
**Multiple Section Louver Installation**



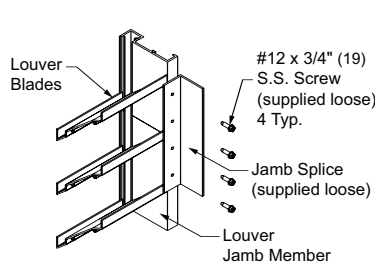
**Fig. 3.1 Clip Angle - Multiple Section Louver**



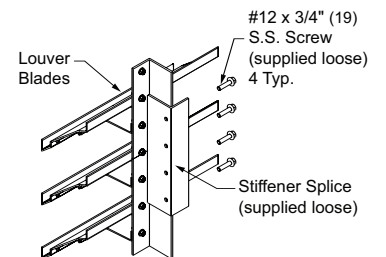
**Fig. 3.2 Visible Mullion**



**Fig. 3.3 Hidden Mullion**



**Fig. 3.4 Jamb Splice**



**Fig. 3.5 Stiffener Splice**