

Application

The ECD-545-MD is engineered and tested to withstand extreme loads, debris impact and cyclic fatigue failure associated with the severe weather effects of hurricanes (Miami-Dade County approval #11-0429.02). Constructed from 6063-T5 extruded aluminum the ECD-545-MD's unique load-bearing design accommodates installations of unlimited width or height and single section assemblies up to 48" x 144" (1219 x 3658) without adding costly intermediate structural supports required by other products. Specially designed water resistant seam covers further enhance performance and aesthetics of this industry leading product.

Standard Construction

- Material:** Mill finish 6063-T5 extruded aluminum.
- Frame:** 5" deep x 0.125" thick (127 x 3) channel.
- Blades:** 45° x 0.081" (2) thick horizontal style.
- Screen:** 1/2" x 0.063" (12.7 x 1.6) expanded and flattened aluminum.
- Mullion:** Visible.
- Minimum Size:** 4.5" x 5" (114 x 127)
- Maximum Size:** Single section: 48" x 144" (1219 x 3658)
Multiple section: Unlimited width x 144" (3658) or 48" (1219) x unlimited height

Options

- Factory finish:
 - High Performance Fluoropolymer - 100% resin Newlar®/ 70% resin Kynar®
 - Baked Enamel
 - Clear or Color Anodized, Class 1
 - Prime Coat
- 1 1/2" (38) flange frame.
- Alternate bird or insect screens.
- Insulated or non-insulated blank-off panels.
- Filter racks.
- Head and/or sill flashing.
- Factory installed sleeve. [Maximum 48" x 144" (1219 x 3658)]
- 5" x 3" x 1/4" (127 x 76 x 6.4) Steel Tube

Ratings

Free Area: [48" x 48" (1222 x 1222) unit]: 7.4 ft² (0.69 m²)
46.3%

Performance @ Beginning Point of Water Penetration

Free Area Velocity: Above 1250 fpm (6.35 m/s)
Air Volume Delivered: Above 9250 cfm (4.37 m³/s)
Pressure Loss: 0.22 in.wg. (55 Pa)

Velocity @ 0.15 in.wg. Pressure Loss: 1030 fpm (5.24 m/s)

Miami Dade County: NOA No. 11-0429.02 (Expires 10/9/2013)
Approved to FBC TAS202-94, TAS201-94 and TAS203-94.

Florida Building Code Approval: No. FL12672

Design Load: 150 psf

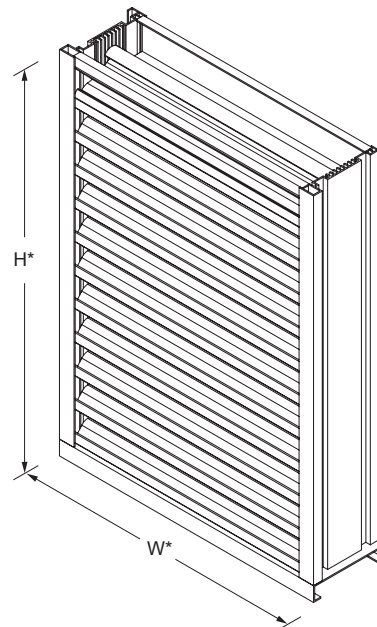

Model ECD-545-MD
(standard)
*Louver dimensions furnished approximately 1/2" (13) undersize.

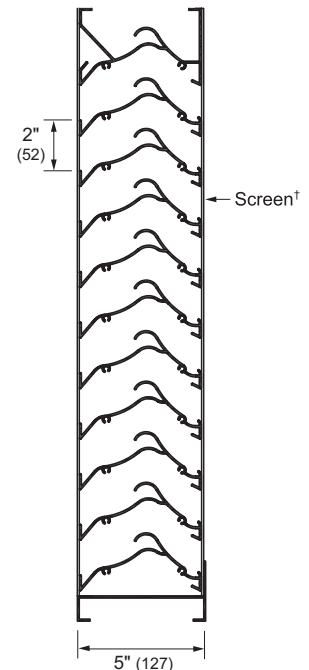

Vertical Section
†Screen adds approximately 3/16" (5) to louver depth.

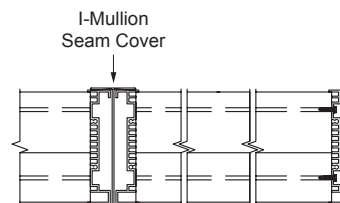

Visible Vertical Mullion
(standard)

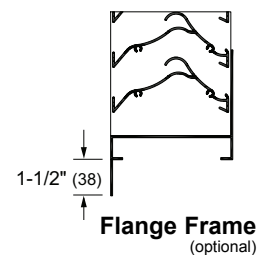

Flange Frame
(optional)

Certified Ratings:

All-Lite certifies that the model ECD-545-MD shown herein is licensed to bear the AMCA seal. The ratings shown are based on test and procedures performed in accordance with AMCA Publication 511 and comply with the requirements of the AMCA Certified Ratings Program. The AMCA Certified Ratings seal applies to air performance, water penetration and wind-driven rain ratings.



Free Area (ft²)

Width (Inches)

	12	18	24	30	36	42	48	54	60	66	72	78	84	90	96	102	108	114	120
12	0.3	0.4	0.6	0.7	0.9	1.0	1.2	1.4	1.5	1.7	1.8	2.0	2.1	2.3	2.5	2.6	2.8	2.9	3.1
18	0.5	0.8	1.1	1.4	1.6	1.9	2.2	2.5	2.8	3.1	3.4	3.7	4.0	4.3	4.5	4.8	5.1	5.4	5.7
24	0.7	1.1	1.6	2.0	2.4	2.8	3.3	3.7	4.1	4.5	4.9	5.4	5.8	6.2	6.6	7.1	7.5	7.9	8.3
30	0.9	1.5	2.0	2.6	3.2	3.7	4.3	4.6	5.4	5.9	6.5	7.1	7.6	8.2	8.7	9.3	9.9	10.4	11.0
36	1.2	1.8	2.5	3.2	3.9	4.6	5.3	6.0	6.7	7.4	8.1	8.8	9.4	10.1	10.8	11.5	12.2	12.9	13.6
42	1.4	2.2	3.0	3.8	4.7	5.5	6.3	7.1	8.0	8.8	9.6	10.4	11.3	12.1	12.9	13.7	14.6	15.4	16.2
48	1.6	2.6	3.5	4.5	5.4	6.4	7.4	8.3	9.3	10.2	11.2	12.1	13.1	14.1	15.0	16.0	16.9	17.9	18.8
54	1.8	2.9	4.0	5.1	6.2	7.3	8.4	9.5	10.6	11.6	12.7	13.8	14.9	16.0	17.1	18.2	19.3	20.4	21.5
60	2.0	3.3	4.5	5.7	6.9	8.2	9.4	10.6	11.8	13.1	14.3	15.5	16.7	18.0	19.2	20.4	21.7	22.9	24.1
66	2.3	3.6	5.0	6.3	7.7	9.1	10.4	11.8	13.1	14.5	15.9	17.2	18.6	19.9	21.3	22.7	24.0	25.4	26.7
72	2.5	4.0	5.5	7.0	8.5	10.0	11.4	12.9	14.4	15.9	17.4	18.9	20.4	21.9	23.4	24.9	26.4	27.9	29.4
78	2.7	4.3	6.0	7.6	9.2	10.8	12.5	14.1	15.7	17.3	19.0	20.6	22.2	23.9	25.5	27.1	28.7	30.4	32.0
84	2.9	4.7	6.5	8.2	10.0	11.7	13.5	15.3	17.0	18.8	20.5	22.3	24.1	25.8	27.6	29.3	31.3	32.9	34.6
90	3.2	5.0	6.9	8.8	10.7	12.6	14.5	16.4	18.3	20.2	22.1	24.0	25.9	27.8	29.7	31.6	33.5	35.3	37.2
96	3.4	5.4	7.4	9.5	11.5	13.5	15.5	17.6	19.6	21.6	23.6	25.7	27.7	29.7	31.8	33.8	35.8	37.8	39.9
102	3.6	5.8	7.9	10.1	12.2	14.4	16.6	18.7	20.9	23.0	25.2	27.4	29.5	31.7	33.9	36.0	38.2	40.3	42.5
108	3.8	6.1	8.4	10.7	13.0	15.3	17.6	19.9	22.2	24.3	26.8	29.1	31.4	33.6	35.9	38.2	40.5	42.8	45.1
114	4.0	6.5	8.9	11.3	13.8	16.2	18.6	21.0	23.5	25.9	28.3	30.6	33.2	35.6	38.0	40.5	42.9	45.3	47.7
120	4.3	6.8	9.4	12.0	14.5	17.1	19.6	22.2	24.8	27.3	29.9	32.6	35.0	37.6	40.1	42.7	45.3	47.8	50.4



Certified Ratings:
 All-Lite certifies that the model ECD-545-MD shown herein is licensed to bear the AMCA seal. The ratings shown are based on test and procedures performed in accordance with AMCA Publication 511 and comply with the requirements of the AMCA Certified Ratings Program. The AMCA Certified Ratings seal applies to air performance, water penetration and wind-driven rain ratings.

Pressure Loss

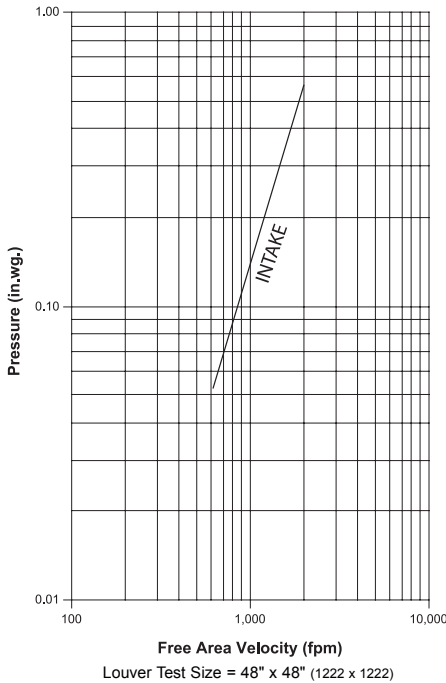

Selection Criteria

Follow the steps listed below to calculate the louver size needed to satisfy the required air volume while minimizing the adverse effects of water penetration and pressure loss.

1. Determine the Free Area Velocity (FAV) at the maximum allowable pressure loss using the *Pressure Loss* chart to the left. While job conditions vary, typically, the maximum allowable pressure loss should not exceed 0.15 in.wg., and the FAV for 0.15 in.wg. pressure loss is listed on the front page of this sheet.

2. **Intake Applications** If the FAV at the Beginning Point of Water Penetration (shown below) is less than the FAV from step 1, then use the FAV at the Beginning Point of Water Penetration in step 3, otherwise use the FAV from step 1.

Exhaust Applications Use the FAV from step 1 in step 3.

3. Calculate the total louver square footage required using the following equation.

$$\frac{\text{Required Air Volume (cfm)}}{\text{FAV (fpm)}} = \frac{\text{Required Louver (Free-Area) Size (ft}^2\text{)}}{1}$$

4. Using the *Free Area* chart above, select a louver width and height that yields a free area ft² greater than or equal to the required louver size calculated in step 3.

Water Penetration

Beginning Point of Water Penetration = Above 1250 fpm

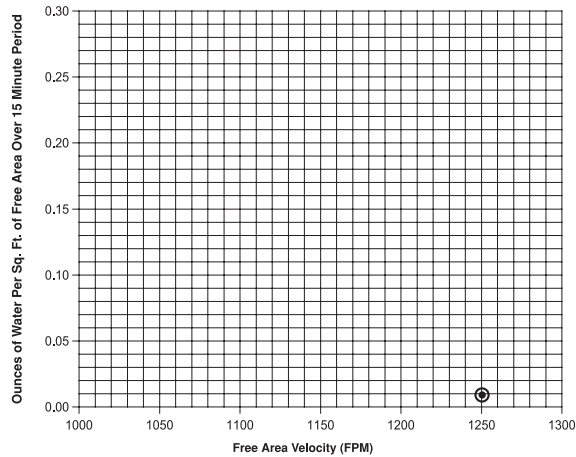

Water Penetration

AMCA defines the beginning point of water penetration as the free area velocity at the intersection of a simple linear regression of test data and the line of 0.01 ounces of water per square foot of free area and is measured through a 48" x 48" louver during a 15 minute period. The AMCA water penetration test provides a method for comparing louver models and designs as to their efficiency in resisting the penetration of rainfall under specific lab conditions. All-Lite recommends that intake louvers are selected with a reasonable margin of safety below the beginning point of water penetration in order to avoid unwanted penetration during severe storm conditions.

Wind Driven Rain Performance — AMCA 500-L Wind Driven Rain Test

Test louver Core Area, is 39 3/8" x 39 3/8".

Wind Velocity	Rainfall	Airflow	Core Velocity	Effectiveness Ratio	Wind Class ₂	Discharge Class ₃
29 mph	3 in/hr	9419 cfm	668 fpm	100%	A	2
50 mph	8 in/hr	9532 cfm	676 fpm	97.9%	B	2

Wind Driven Rain Class	Effectiveness
A	1.000 to 0.99
B	0.989 to 0.95
C	0.949 to 0.80
D	0.799 to 0.00

NOTES

1. Core Area is the open area of the louver face (face area less louver frame). 2. Wind Driven Rain Penetration Classes. 3. Discharge Loss Coefficient is calculated by dividing the louvers' actual airflow rate by the theoretical airflow rate for an unobstructed opening. The higher the coefficient the lower the resistance to air flow.

Information is correct at time of printing. However, we reserve the right to make changes without notice.

NOTE: Dimensions in parentheses () are millimeters.